

**QUALI
MATION**

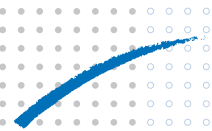

LANGHANS INNOTECH

« A GOOD CAN IS BORN WITH A GOOD BLANK »

What is a good blank?

1. the coating on the correct position
2. no lacquer on the margin
3. the blank squareness in tolerance
4. blank length and width in tolerance

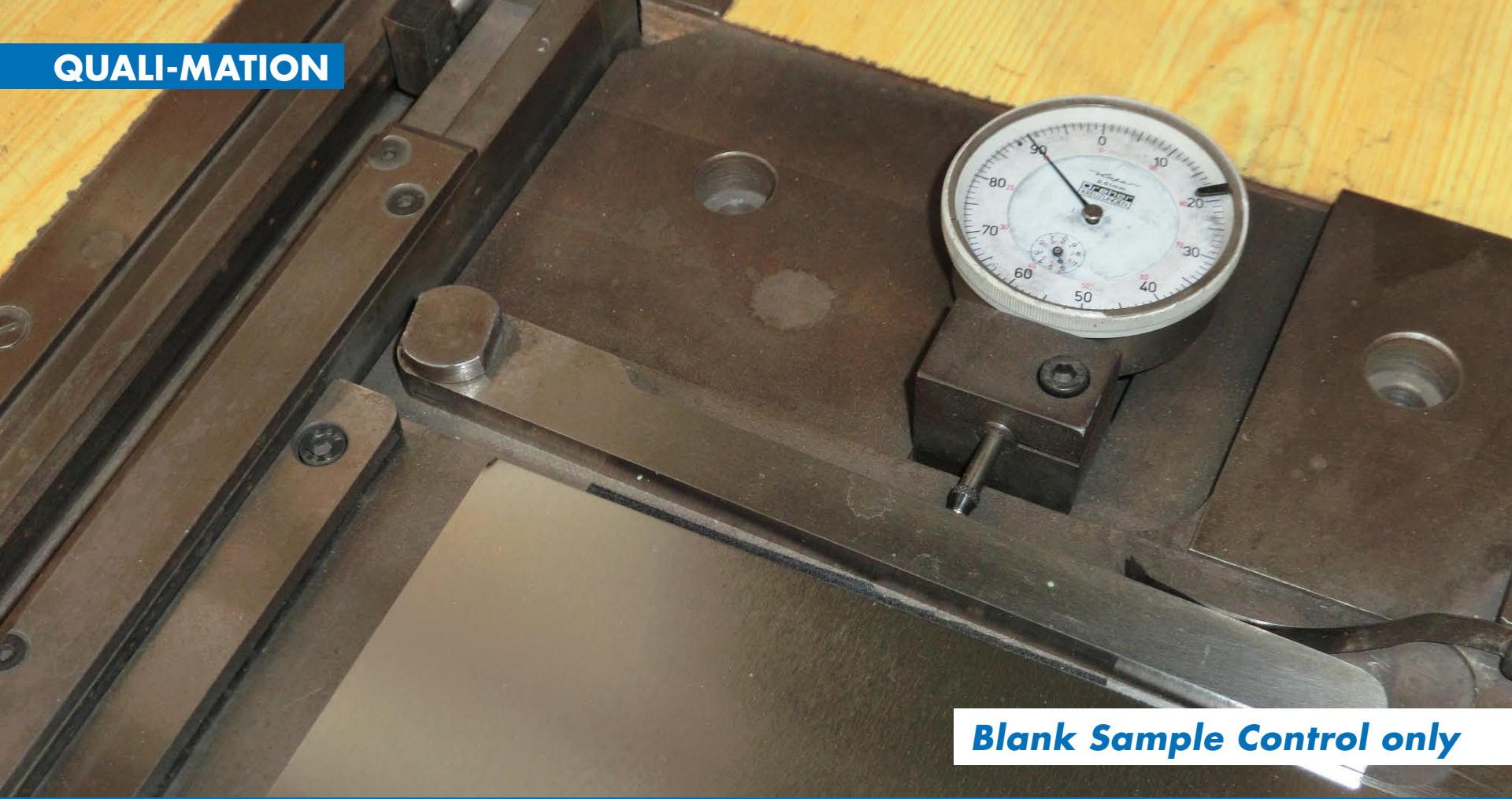

Blank Sample Control only

QUALI-MATION



Blank Sample Control only



0.1%

State of the art and most common is still Off-Line Quality control only. Just very few samples are checked, **max. 0.1%** of produced volume. The big rest of 99.9% production keeps being uncontrolled.

319 0351
07753V02

Overlap lost





Automation in Quality Blank Production = Quali-Mation

But how to reach the Quali-Mation standard?

Quali-Mation means the combination of In-Line Quality Control devices SQM and LMC, with Automatic Separating systems SSS or SBR.

This combination enables the uninterrupted production of proofed quality with the certainty, that only good quality is reaching the next step in the canmaking process.

QUALI-MATION

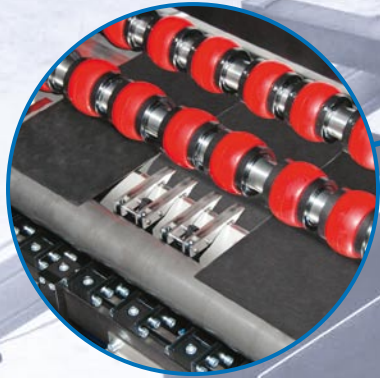

In-Line Quality Control

SQM in combination with SBR

QUALI-MATION

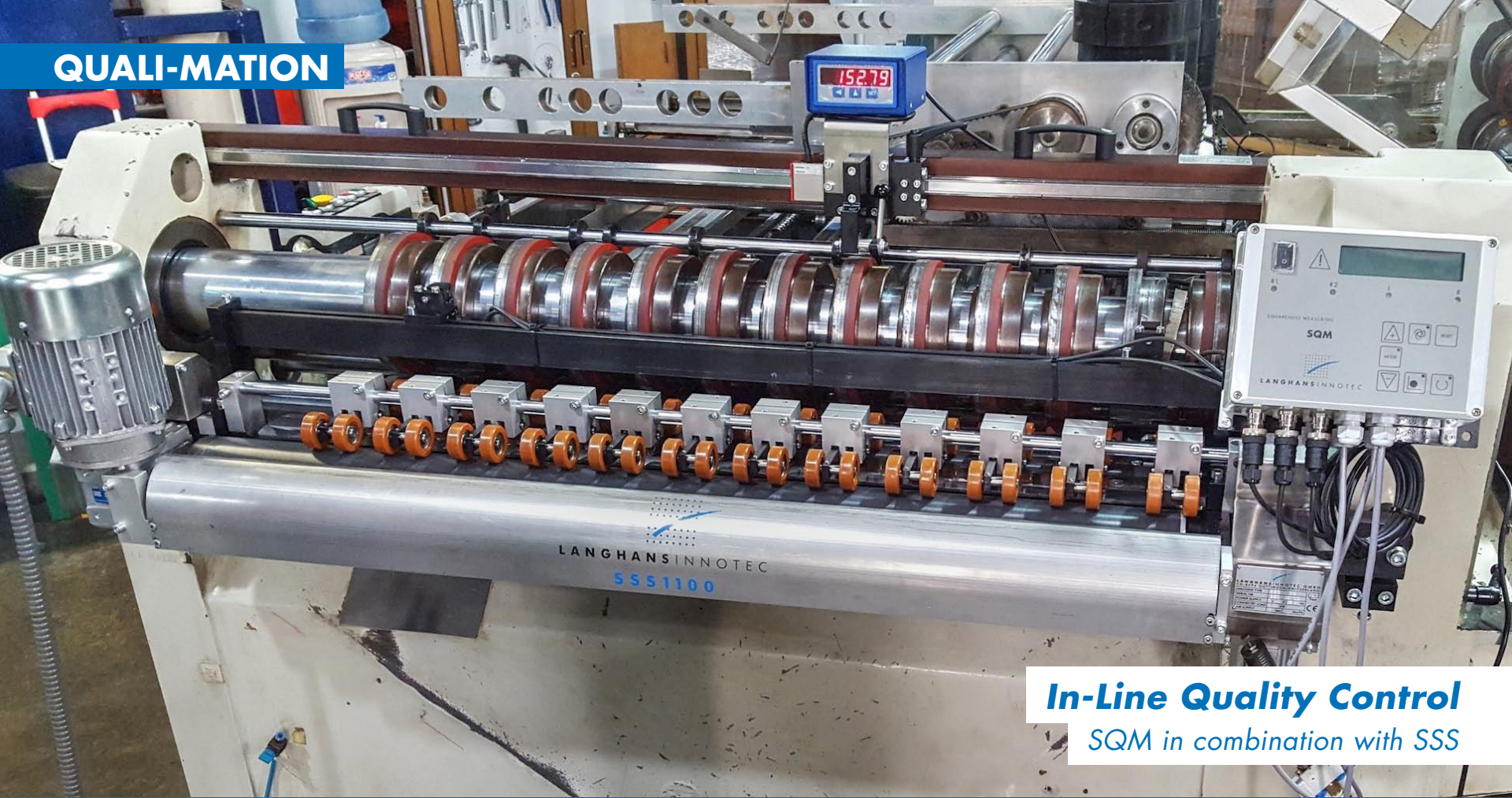

In-Line Quality Control
SQM in combination with SSS

In-Line Sheet Length Control

- SQM2 with 2 Array Sensors
- in combination with SSS Rejection Station

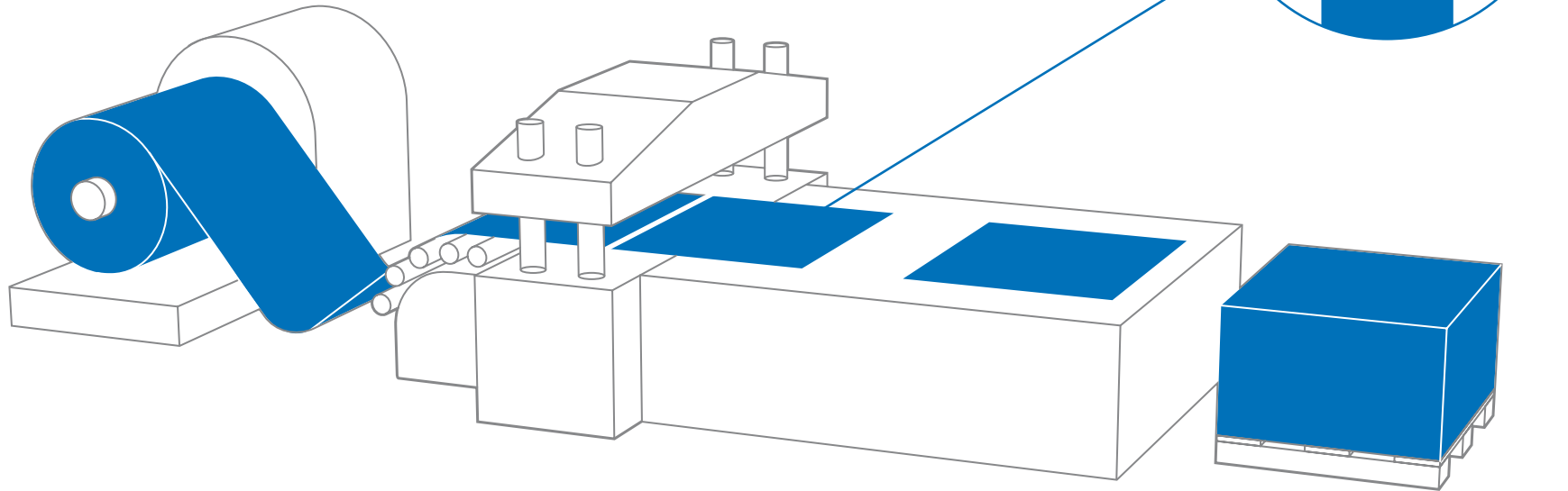

In-Line Sheet Position Control

- SQM2 Litho with 3 Laser Sensors and 1 or 2 Array Sensors
- in combination with SSS Litho Rejection Station

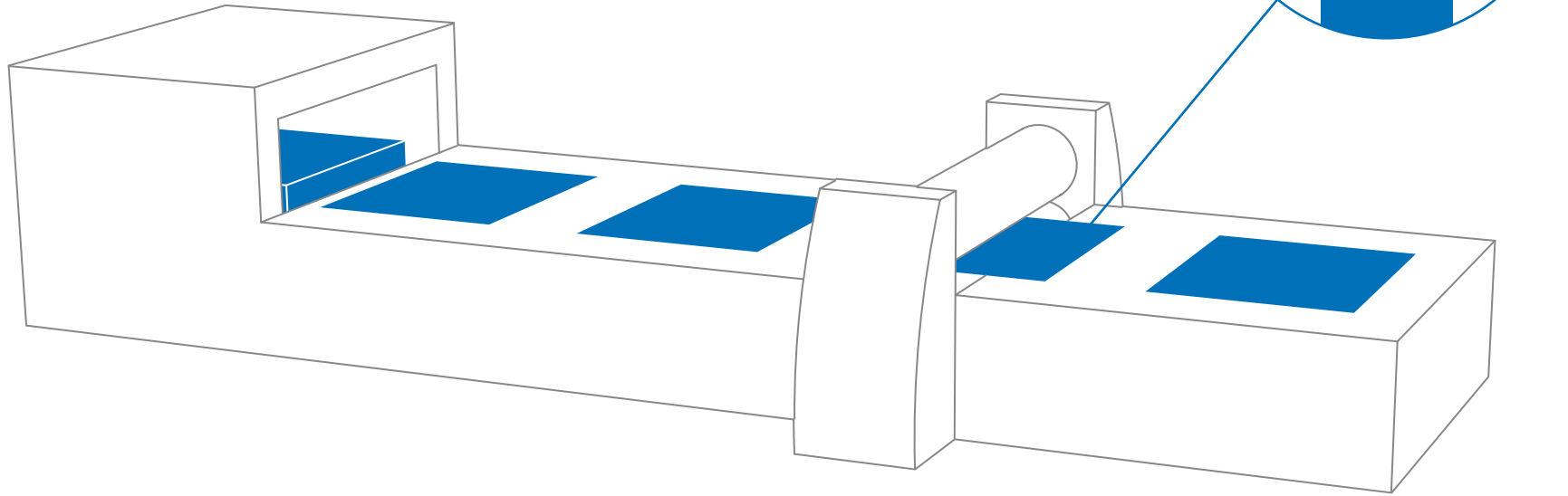

QUALI-MATION Slitting Line - Guillotine Slitter

In-Line Strip Width Control

- SQM2 with 2 Array Sensors

1st op.

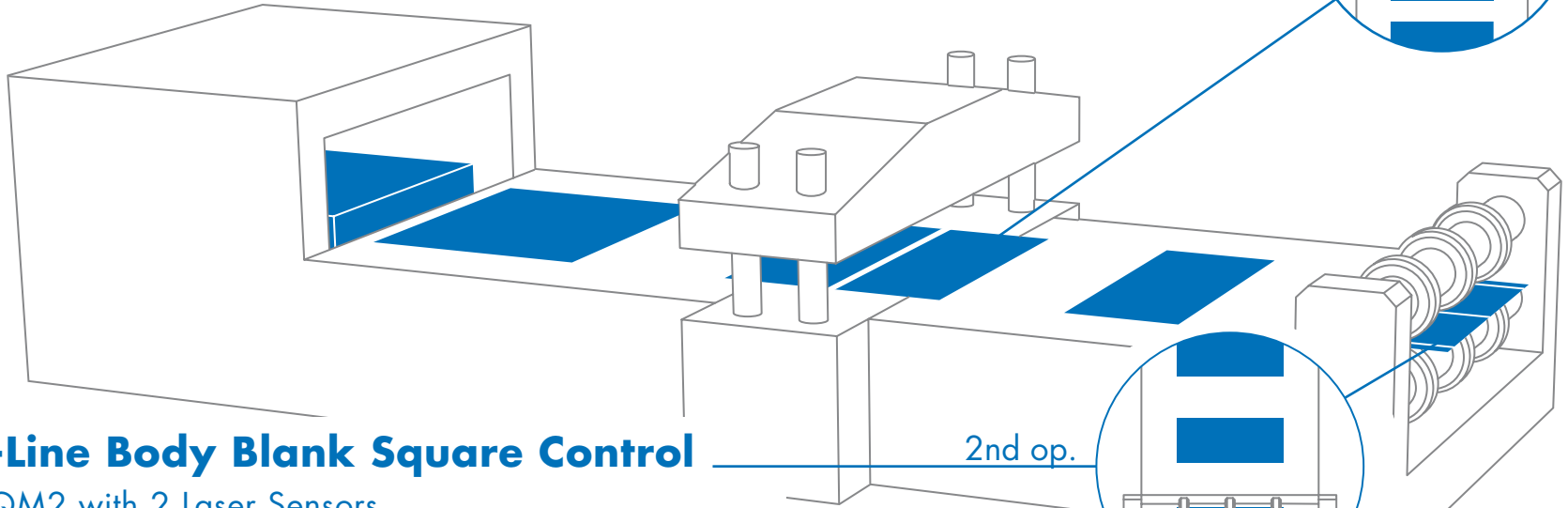
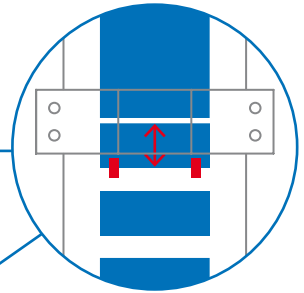

In-Line Body Blank Square Control

- SQM2 with 2 Laser Sensors
- in combination with either SSS or SBR Rejection Station

2nd op.

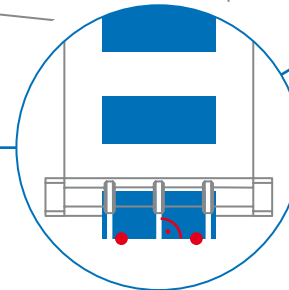

QUALI-MATION Slitting Line - Duplex Slitter

In-Line Lacquer Margin control

- LMC system with 1-9 Margin Scout Sensors

1st op.

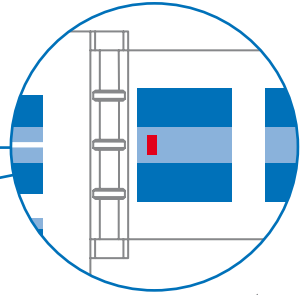

2nd op.

In-Line Body Blank Square Control

- SQM2 with 2 Laser Sensors

- in combination with either SSS or SBR Rejection Station

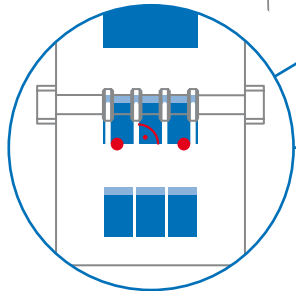



100%

**Quali-Mation is no luxury,
it simply makes sense and safes your money.**

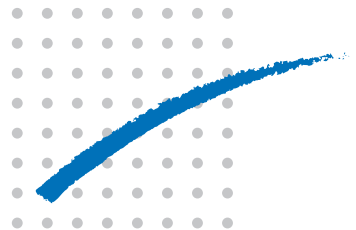

LANGHANS INNOTEC

Langhans Innotec GmbH · Lagerhausstrasse 20 · CH-8594 Güttingen · Switzerland

Tel +41 71 870 07 80 · Fax +41 71 870 07 81 · contact@langhansinnotec.com

www.langhansinnotec.com