

Valk Welding Group  
Postbus 60  
2950 AB Alblasserdam

Tel +31 78 69 170 11  
info@valkwelding.com  
www.valkwelding.com



Valk Welding  
robot solutions





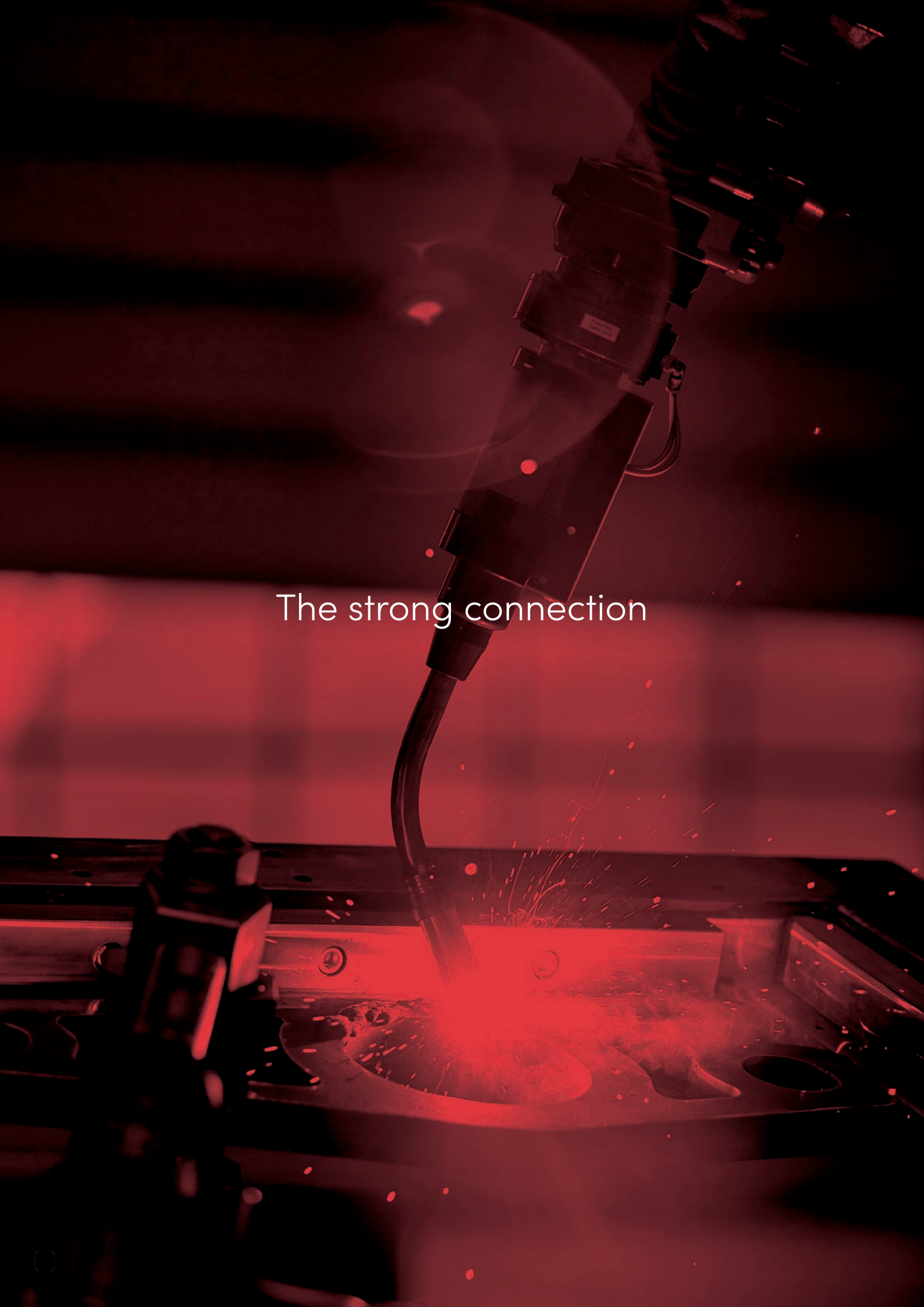

The strong connection

## Valk Welding robot solutions – Technology partner for arc welding robot systems for small to medium sized series

Valk Welding develops and builds turnkey welding robot systems for small to medium production requirements. Valk Welding has installed over 3800 industrial robots, and delivers over 800 metric tons of welding wire each month making it one of Europe's largest independent suppliers. From its head office in the Netherlands and its own facilities in France, Czech Republic, Germany and Denmark, Valk Welding serves the entire European metal industry with local demonstrations, sales, distribution, trainings and service facilities. With its efficient and flexible organisation, Valk Welding will respond quickly to your demands.

The strong connection	4	Seam searching	20
Welding robot TM-series	6	Seam tracking	21
Panasonic TAWERS series	7	Automation accessoires	22
Leading in Welding Technology	8	Safety	23
VWPR QE MIG and TIG torches	10	Supporting software	24
Frame solutions	12	Technical training	25
Track-frame solutions	14	Trouble-free Wire feeding	26
Track solutions	16		
Positioners, positioner frames and beams	18		





## The strong connection

### Why Valk Welding

Valk Welding as technology partner makes the difference with the supply of total solutions, custom "built" systems, user-friendly offline programming systems, robots specifically designed for the arc welding process, tooling, wire feed systems, high quality welding wire and welding and robot technology know-how.

Some facts about Valk Welding:

- 1 family owner
- 5 facilities with sales and service
- 9 companies in Europe (Netherlands, Belgium, France, Germany, Czech Republic, Denmark, Sweden, N-Ireland and Poland)
- 194 enthusiastic employees
- 200 robots per year
- > 800 tons welding wire per month
- > 1.500 offline programming licenses
- > 1.900 years of experience
- > 3.900 installed base of robot systems

### Standard and custom-build

Valk Welding develops innovative solutions to solve your problem. We think along with you, so that together we can achieve the best result. We supply all-in-one welding robot systems, but above all we

offer solutions! Our solution consists of three components: the robot, the construction and a software package. Everything from one source and the ideal total solution for your company.

As well as complex and customer-specific solutions Valk Welding offers a comprehensive range of 'standard' robot concepts. With competitive pricing and modular designs, Valk Welding offers high performing flexible production solutions with these concepts. Valk Welding's engineering team develops concepts based on your requirements aimed at achieving the highest possible production performance. Valk Welding has engineers specialised in welding automation and software development for custom built welding and cutting robot systems. The assembly of all our robot systems is completed in our own facilities, where training courses will be provided for your operators and programmers.

### Robots designed for welding

**Panasonic** robots are specifically developed for the arc welding process in which all components and software are produced in-house. The welding robot, welding machine, controller, wire feeder, positioners and software are therefore optimally tuned to each other. And last but not least: we take all responsibility together with **Panasonic** for your whole project.

### Software solutions

To get the most out of your robot installation, the interaction between man and machine is very important. Valk Welding has developed various software solutions that ensure both quick control of the robot and communication with your employees. To make the use of welding robots possible in small series and single-piece production, Valk Welding is investing heavily in the development of software modules. The programming and simulation software DTPS, developed in close collaboration with **Panasonic** specifically for welding robotisation, also forms the base for further automation of the programming process. We also have solutions for fully automatic programming of your parts. With the development of Shop Floor Control systems and Management Information tools, including full traceability, Valk Welding responds to the further demand for Industry 4.0 solutions.

### Valk Welding high-grade welding wires

Valk Welding helps you from A to Z, we help you further with your welding robot installation. A welding robot can not run without a welding wire. Valk Welding has grown into one of the largest independent suppliers of welding wire in Europe. Every month Valk Welding supplies more than 800 tons of (solid) welding wire. Valk Welding delivers most consumables from stock where possible within 24 hours, from Valk Welding's logistics centers in the Netherlands, Denmark, France and the Czech Republic.

### Valk Welding robot torch

Valk Welding uses its own internally developed VWPR welding equipment. This equipment covers all the needs from wire feeder to the arc: longlife quick exchangeable cable assemblies, unique pneumatical shock sensors, torch bodies with patented wire clamping and water-cooled robotic torch with quick exchange standard and custom made goose necks. This integral solution is vital to drastically increase the overall equipment efficiency of your investment.

### Reliable wire feeding

In order to ensure the quality welding wire reaches the wire feeder without interference, Valk Welding supplies a complete range of wire feed systems. This program of Wire Wizard offers solutions to connect all types of drums of welding wire with all brands of robots. The patented wire cables, the Pneumatic Feed Assist and the Wire Guide Modules, which ensure a friction free transport of the welding wire, are a crucial part of the low-maintenance system.



See our video "The people behind"

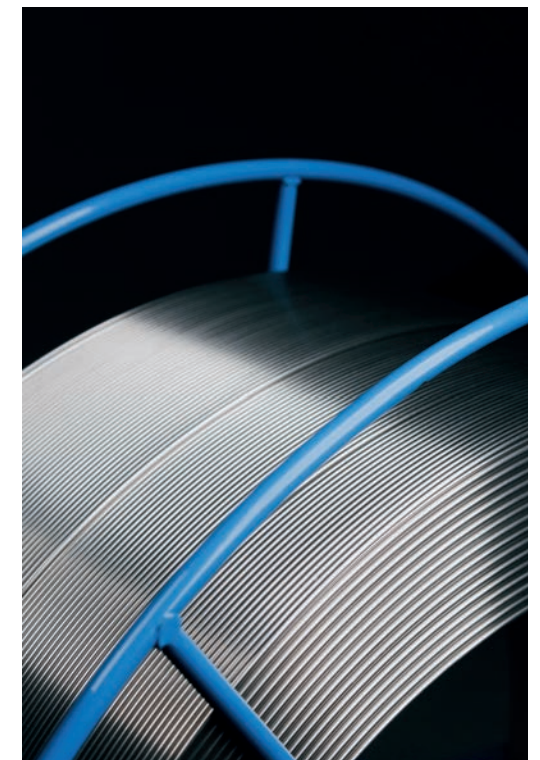



# Panasonic

## Welding robot TM-series

- State-of-the-art welding robot.
- Same high performance as the TL-series.
- Suitable for Super Active Wire Process.
- Compatible with external, internal and hybrid VWPR cable assemblies.



### TM-series with internal or external cable assembly

The basic model of the TM-series is available with the longlife quick exchangeable Valk Welding VWPR cable assembly through the robot arm (internal, with focus on reducing cable interference) and outside the robot arm (external with focus on wire feedability).

### TM-series with hybrid cable assembly

Moreover, the welding robots program turns to the hybrid solution, in which only the welding wire cable runs outside the robot arm, and the welding current cable, shielding gas, compressed air and water cooling go through the robot arm. The hybrid cable assembly is the perfect answer to the high-speed Panasonic robots because of less weight and more flexibility for optimal reachability of your parts, leading to longer lifetime of the cable assembly and ensuring you the highest wire feedability.

Internal cable assembly



External cable assembly



Hybrid cable assembly



## Welding robot TL-series

- Higher payloads.
- Symmetrical design for optimal mirroring of robot programs.
- External cable assemblies only.



## Welding robot TS-series

- Floor, ceiling and wall mount High speed.
- 48% smaller footprint.
- Suitable for Super Active, TAWERS-TIG/TAWERS.



## Welding robot LA-series

- Worldwide best-in-class for load, speed and reach.
- High accuracy welding and handling.
- Synchronous with welding robot for jigless welding.



# Panasonic

## TAWERS series

### All-in One Arc Welding Robot Solution

The performance of the welding robots from the **Panasonic** TAWERS™ series enables you to influence important factors of your business management, such as quality, accuracy, flexibility and cycle times, so an optimal efficiency from your welding automation can be achieved.

	Max. payload	Max. reach	Max. speed	Repeatability	Robotweight
TM-1100	6 kg	1.163 mm	180m/min.	+/- 0,08 mm	+/- 156 kg
TM-1400	6 kg	1.437 mm	180m/min.	+/- 0,08 mm	+/- 170 kg
TM-1600	4 kg	1.639 mm	180m/min.	+/- 0,08 mm	+/- 180 kg
TM-1800	6 kg	1.809 mm	180m/min.	+/- 0,08 mm	+/- 215 kg
TM-2000	6 kg	2.011 mm	180m/min.	+/- 0,1 mm	+/- 217 kg
TL-1800	8 kg	1.801 mm	180m/min.	+/- 0,08 mm	+/- 215 kg
TL-2000	6 kg	1.999 mm	180m/min.	+/- 0,15 mm	+/- 216 kg
TS-800	8 kg	841 mm	180m/min.	+/- 0,05 mm	+/- 55 kg
TS-950	8 kg	971 mm	180m/min.	+/- 0,05 mm	+/- 56 kg
LA-1800	26 kg	1.801 mm	180m/min.	+/- 0,07 mm	+/- 320 kg
HH-020L	20 kg	3.281 mm	180m/min.	+/- 0,15 mm	+/- 535 kg
YS-080G3	80 kg	2.240 mm	180m/min.	+/- 0,15 mm	+/- 620 kg
HS-220G3	220 kg	2.666 mm	180m/min.	+/- 0,15 mm	+/- 955 kg

## Welding robot HH-020L

- Max. payload 20 kg.
- Max. reach 3.281 mm.
- Realize almost same welding ability as the TM/TL series.



## Handling robot YS-080G3

- Max. payload 80 kg.
- Max. reach 2.240 mm.
- Synchronous with welding robot for jigless welding.



## Handling robot HS-220G3

- Max. payload 220 kg.
- Max. reach 2.666 mm.
- Synchronous with welding robot for jigless welding.





## Leading in Welding Technology

**Panasonic** is constantly working on the development of welding processes, with which **Panasonic** can offer the best fitting welding process for every application.

### Fusion of robots, robot controller, power source and servo wire feed in one unit.

- Faster, better and worldwide unique.
- Everything from one manufacturer.
- “Fusion technology” of TAWERS: the robot controller is fused with the welding power source controller.
- All control parameters are combined on a 64-bit CPU PCB.
- 250 times faster communication, eliminating any delay in information flow between the individual components.
- The result is unique and allows many special functions to increase the quality and productivity.

### A small summary of the standard functions

- Automatic restart function in case of a refusal of the start.
- Torch angle display for uniform welding .
- Flying start function to decrease cycle times.
- Automatic wire retract function to ensure a perfect start at the next seam.

### What’s in for you

- Integrated interface.
- Different welding processes with only one power source, even TIG with cold and hot wire.
- Reduction of production costs.
- High processing speed.
- Extreme user-friendly interface.
- Weld data monitoring and recording.
- Weld parameter selection through Weld Navigator function.
- Spatter and heat input reduced thanks to 100 kHz inverter technology .
- Thin and thick plate welding with one power source.
- First time right welding.

- Weld Navigation, your guideline to the perfect weld parameters to get the best results.
- Stitch Welding and LowPulse Welding.

### Some interesting controller software options

- TAWERS Synchronous weaving low-pulse and spiral weaving software.
- **Panasonic** TAWERS Arc Braze Welding Software.
- **Panasonic** HD Mag process for Stainless Steel.
- **Panasonic** Ferretic Stainless Steel software.
- **Panasonic** Zi-Tech software (Zi-Pulse / Zi-Active).
- **Panasonic** TAWERS Stitch Pulse Welding Function
- **Panasonic** TAWERS Pulse Mix Welding Function.
- **Panasonic** Hot Active software for Active Wire Process.
- AEC (Automatic Extension Control)for **Panasonic**.
- Through the arc seam tracking system for WG and WGH series.
- **Panasonic** Thick Plate Software with Middle plate touch sensor software , Thick plate touch sensor software, Thick plate welding software and Welding Condition Editor (WCE).
- Parallel Sequence PLC function for G3 controller.
- Teaching Update Logging function (G3/WG/WGH).

### Standard unique welding processes on WG (350A) and WGH (450A) controller

#### Super imposition control SP-MAG process

- For steel and SUS for 1-2 mm sheet applications.
- Drastic reduction of the weld spatter (up to 90% reduction).
- Highest seam quality with low heat input.

#### Hyper Dip HD Pulse process

- As of 3 mm sheet metal.
- Improved penetration.
- Higher quality.
- Drastic reduction of the weld spatter.
- Higher deposition by using the mix of short circuit and pulse welding.
- Highly reduced risk of undercut.

#### TAWERS ALU MIG process

- For high quality of aluminum. For this process we advice the Valk Welding Servo Pull solution.
- Optimal heat control with synchronised Low Pulse and Spiral Weaving.

#### TAWERS DC TIG process

- With or without cold wire thanks to the standard servo controlled wire feeder and 100 kHz inverter.
- Lift Arc and HF start.

#### HD-MAG welding process

- For improved gap filling without more heat input.

#### Zi-Tech process

- For improved welding quality on zink coated steel plates.

#### Brazing process

- For MIG brazing with special welding wires.

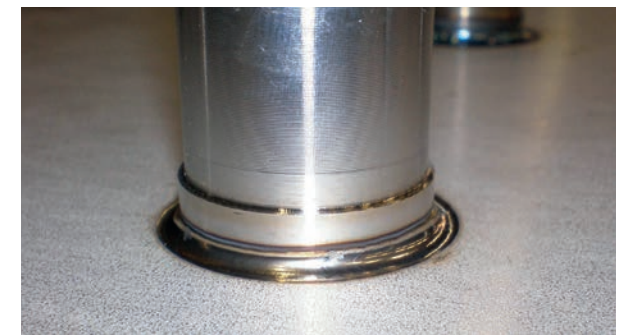

TAWERS TIG

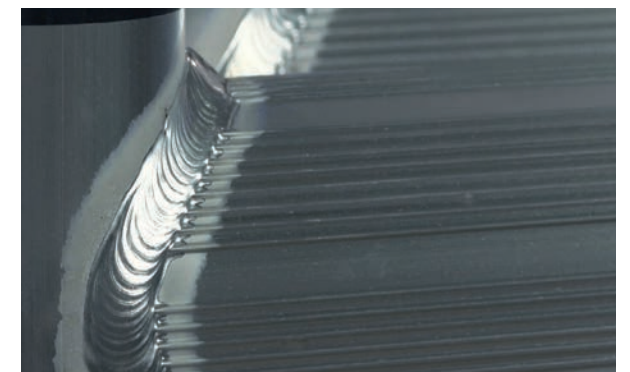

### Panasonic Super Active Wire Process: The cold welding process for best quality

- For thin sheet applications (less than 2 mm).
- Almost spatter free welding in general and strong reduction of projections in unfavorable torch settings.
- Adhesion reduction of projections due to very small spatter volume and finer grain size.
- Higher welding speeds by increased drop transfer in the arc and very low pool vibrations.



SP-MAG process



Hyper Dip Pulse process

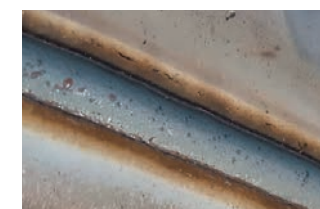

Zi-Tech process



HD-MAG welding process



## VWPR QE MIG and TIG torches

Valk Welding produces its own robotic torch for its own welding robot systems, complete with pneumatic shock sensor, longlife cable assembly, patented wire clamp mechanism and quick change gooseneck. This makes it unnecessary to reprogram or correct existing programs again.

- Calibrated to assure a correct tool center point.
- Quick Exchange (QE) goose neck.
- All VWPR standard and non-standard goose necks compatible with standard VWPR body to increase your flexibility.
- 3D torch protection in case of a collision.
- Adjustable protection according to your needs.

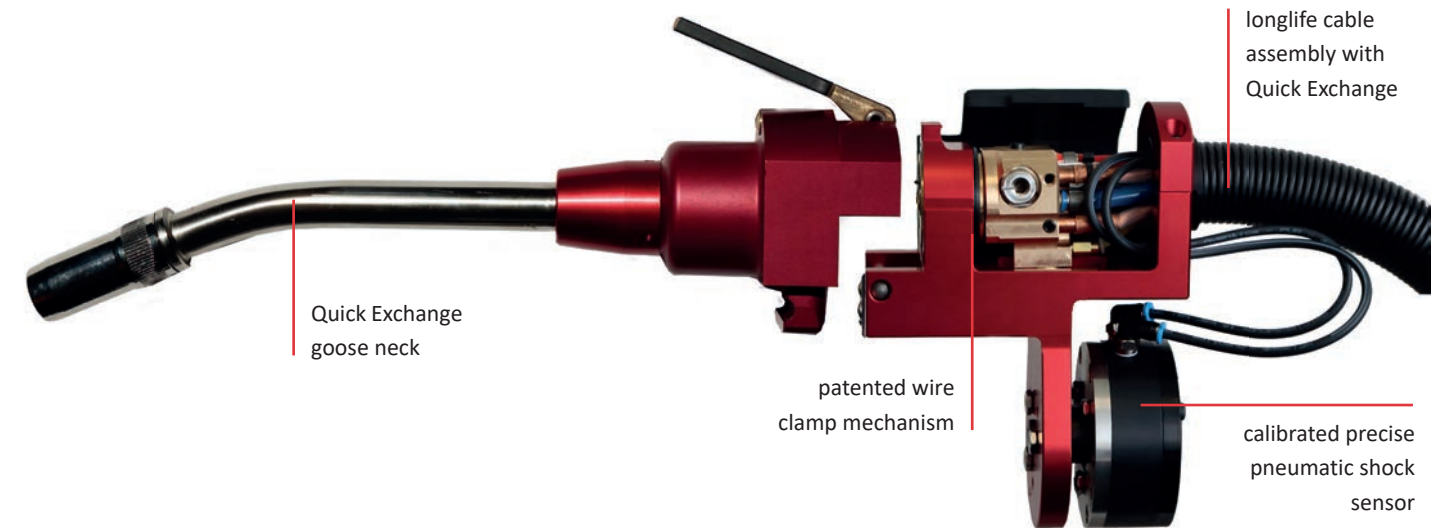

VWPR QE External with MIG II 45 degrees



VWPR QE External with VWPR 500 FE (Fume Extraction)



VWPR QE Internal with MIG II 45 degrees

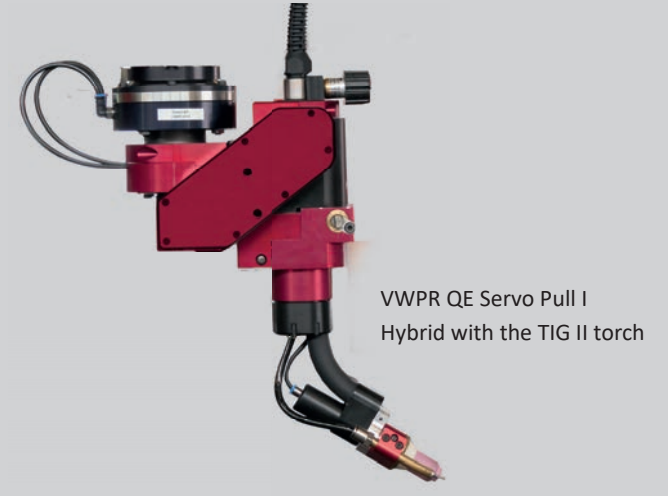

VWPR QE Servo Pull I Hybrid with the TIG II torch



VWPR QE TIG III torch



VWPR QE MIG II torch 22,5 degrees



VWPR QE MIG II torch 45 degrees



Servo pull III with the MIG II torch

### MIG II Torch

- a new construction with less wear parts and therefore less maintenance
- "Quick Exchange" VWPR adapter compatible with the already existing VWPR welding equipment
- Universal mounting of the gas head
- 3 positions of the contact tip possible: protruding past the gas head, flush with the gas head or recessed
- long contact tips and optimal cooling of the contact tip holder
- Valk Welding standard liners
- completely separated from the welding wire, supply of the shielding gas up to the contact tip
- Tool Centre Point (TCP) remains the same

In view of its major advantages, this torch is the right choice for all MIG applications.

### The highest achievable in welding: the Valk Welding VWPR Servo Pull solution

Thanks to the servo-controlled wire feeding at a very short distance from the welding process, we take the MIG as well as the TIG welding process with cold or hot wire to the highest level for you by eliminating the moving of the wire in the cable assembly." This latest development takes, in combination with the TAWERS platform where the robot, power source and wire motor are controlled with one CPU, your welding application to an unknown higher level.

## Frame solutions

Valk Welding was the first with mobile fully machined rigid frames as the basis of their robot systems. This not only reduces the set-up time (lower costs and less disruption to your production), also the robot system can be programmed in advance at Valk Welding. Moreover, optimising your production internally is very easy as you can move the entire system yourself. Thanks to this development and our unique calibration system for robots, exchanging production between different systems or production plants is straightforward and does not require reprogramming to start production immediately.

FRAME-H

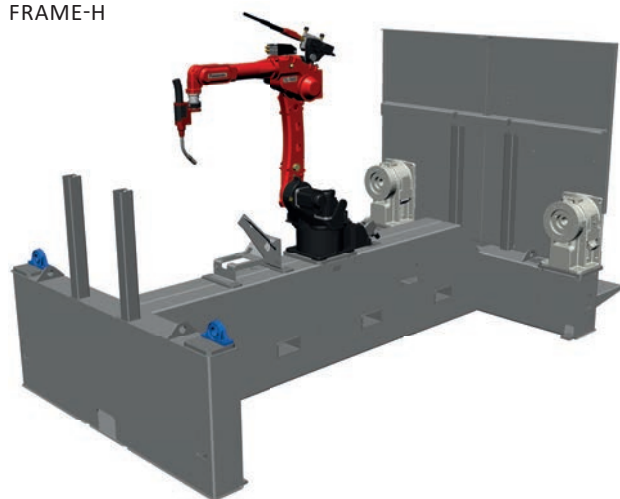

FRAME-C

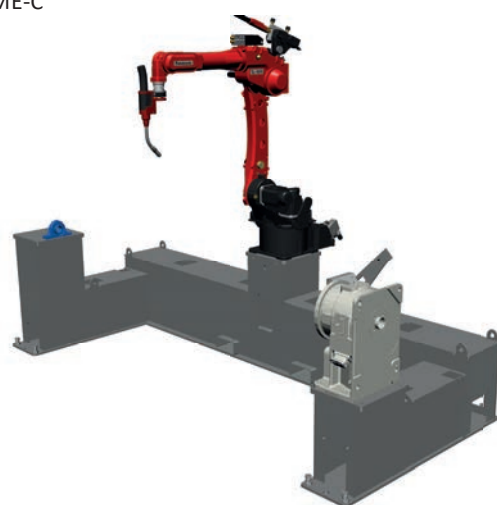

FRAME-IT  
with indexing table

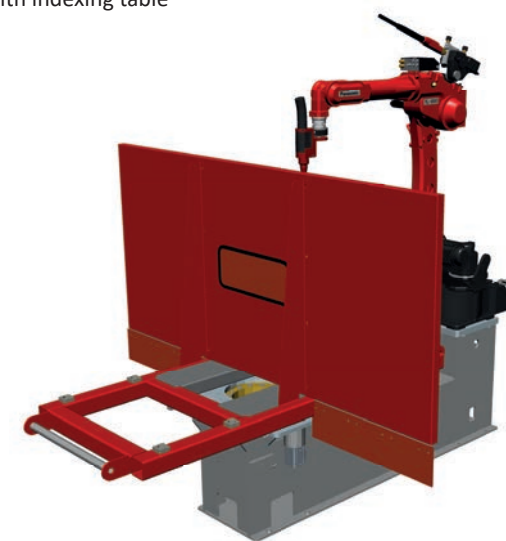

FRAME-IT+H with  
turning table and robot  
in the middle

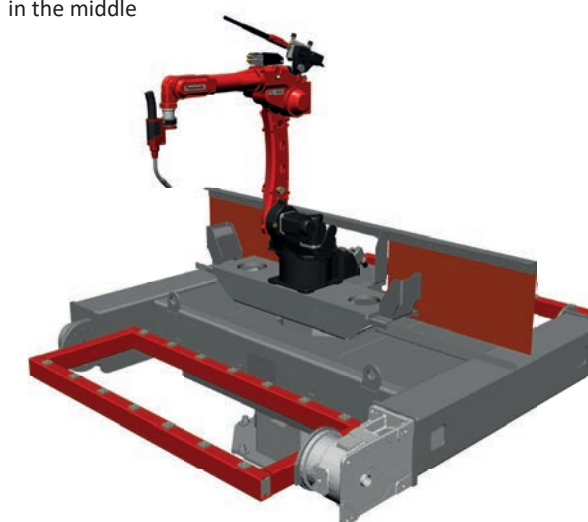

FRAME-E

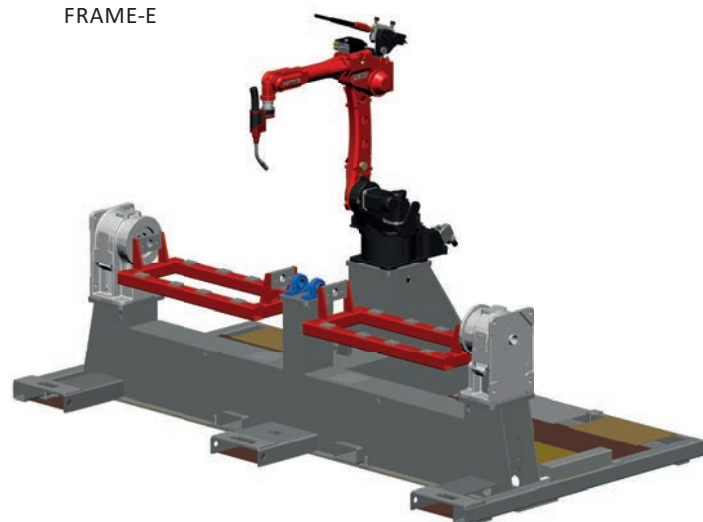

FRAME-C+FW  
(Ferris Wheel)

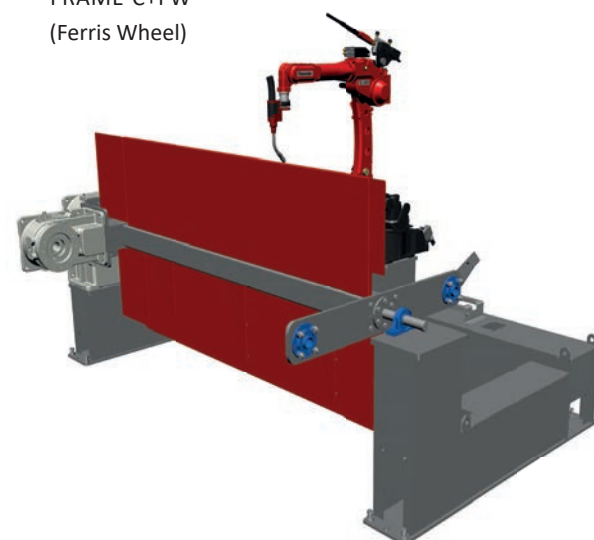

FRAME-IT+L  
with L-positioners



FRAME-IT+H with  
turning table and  
robot at the back side

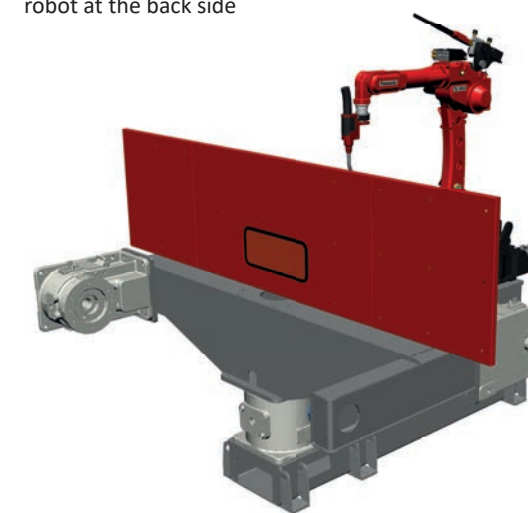



## Track-frame solutions

Track Frames are equipped with a longitudinal track for the robot. This offers the perfect combination of the advantages of a longitudinal track (optimal accessibility and larger workpieces) and a frame concept (movable just like the frame solutions). The track frames can be machined up to 12 meters in one go. Optionally, both the counter bearing and the manipulator are freely adjustable along the length of the installation so that the size of the workstation can be easily adapted to the dimensions of your product or welding jig.

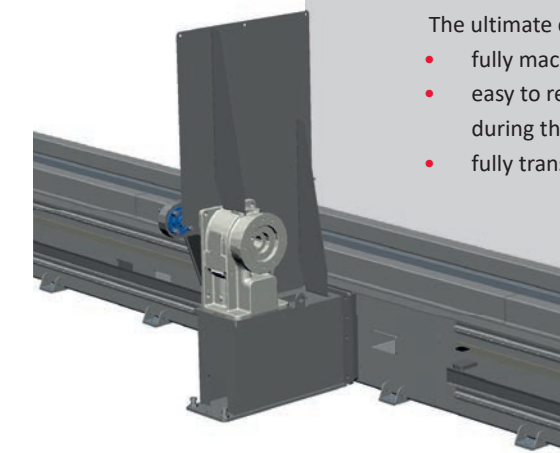

### TRACK-FRAME-EFLEX

The ultimate concept flexibility.

- fully machined components
- easy to reconfigure depending on your needs during the life time of your system
- fully transportable

TRACK-FRAME-E

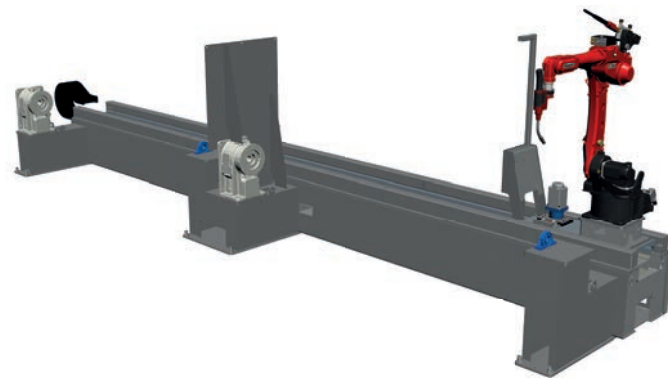

TRACK-FRAME-E SPECIAL

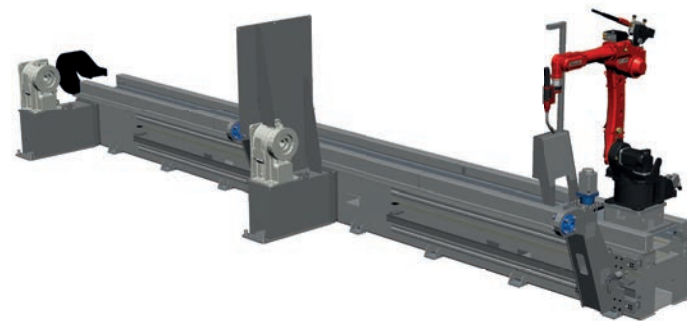

TRACK-FRAME-C

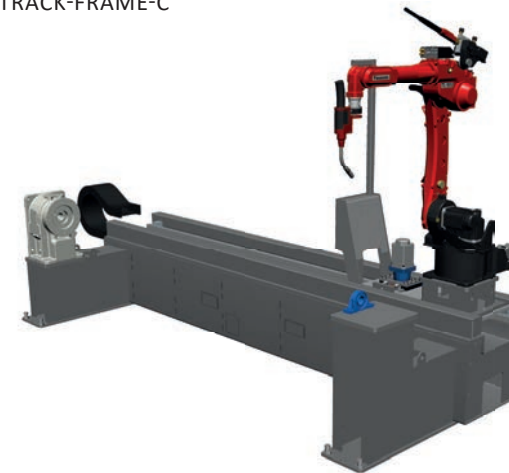

TRACK-FRAME-C+FW  
(Ferris Wheel)

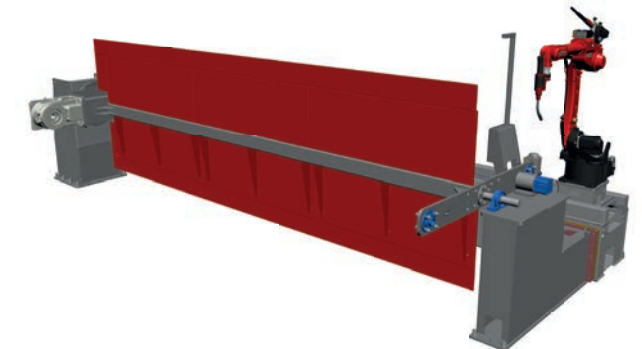

TRACK-FRAME-EE

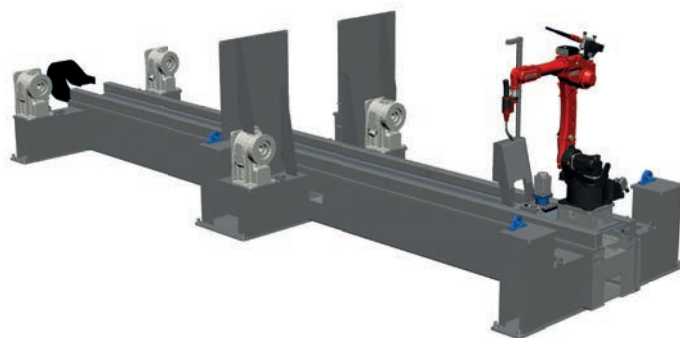

TRACK-FRAME-H

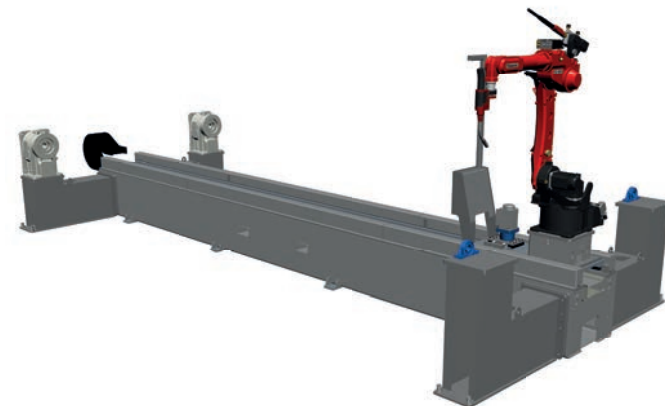

TRACK-FRAME-C-MCB  
(Movable Counter Bearing)

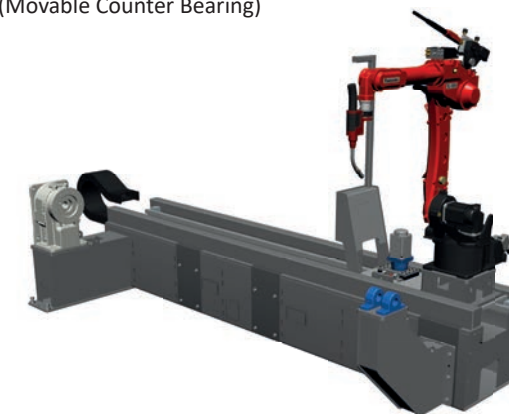

TRACK-FRAME-Z-MCB  
(Movable Counter Bearing)

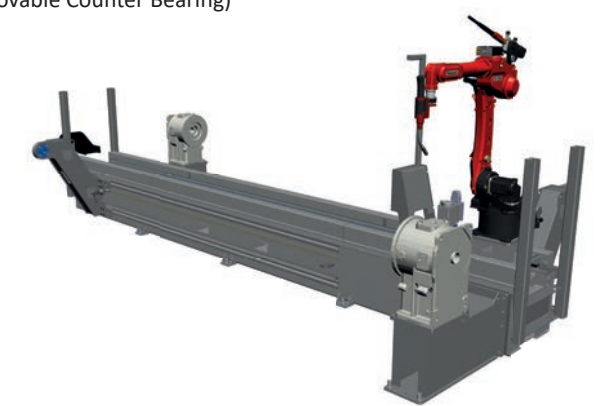



# Track solutions

With the focus on 100% offline programming, our longitudinal tracks meet the highest quality requirements in terms of accuracy and long lifespan. With more than 40.000 metres of shifter functionality already delivered, our custom-made standard concepts have proven themselves and we keep on working on higher quality and additional options. Below you will find a selection of our FS, FH and PH series.

## Singel axis track

### Track FS series

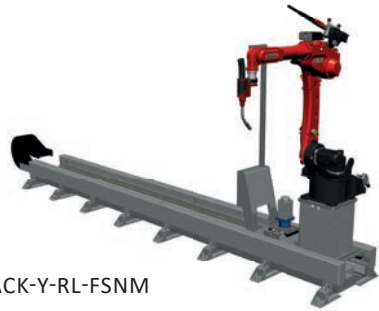

TRACK-Y-RL-FSNM

### Track FH series

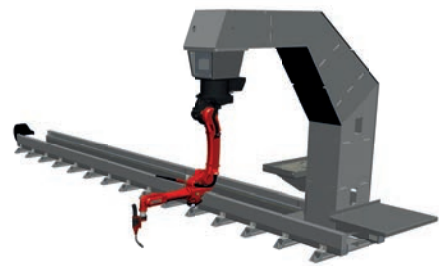

TRACK-Y-RL-FHM

### Track PH series

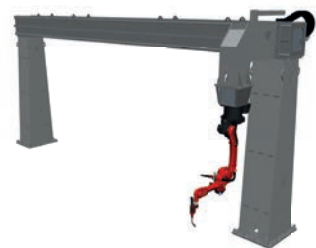

TRACK-Y-RL-PHM

## Double axes track

### Track FH series



TRACK-YX-RL-FHM



TRACK-YZ-RL-FHM-BACK

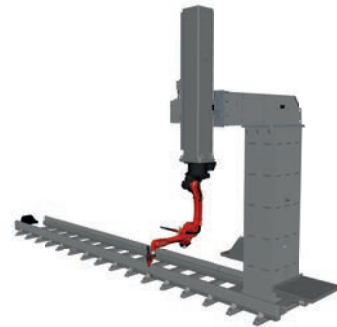

TRACK-YZ-RL-FHM-FRONT



TRACK YR-RL-FHM

## Triple axes track

### Track FH series

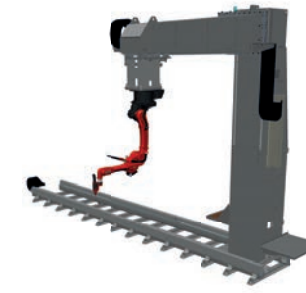

TRACK-YZX-RL-FHM-BACK



TRACK-YRZ-RL-FHM

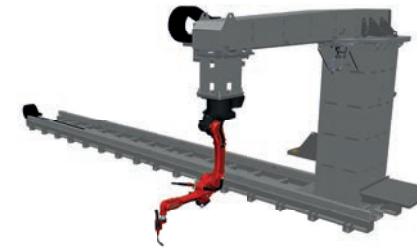

TRACK-YRX-RL-FHM



TRACK-YXZ-RL-FHM

### Track PH series



TRACK-YXZ-RL-PHM





# Positioners, positioner frames and beams

Positioner frames and beams for exact positioning of the welding jigs or parts. Frames and beams fix mounted in the positioner or easy to exchange with the optional quick exchange solution.



From 250 KG TO 10.000 kg

Name	POS250	to	POS10.000
Max. payload (kg)	250		10.000
Max. payload with tail stock or in gantry (kg)	500		20.000
Max. rotation speed (r/min)	30		1,11
Allowable rotational torque (Nm)	196		25.000
Allowable tilting torque (Nm)	1.470		35.000
Repeatability at R=250mm (mm)	+/- 0,05		+/- 0,1
Diameter of hollow shaft (mm)	55		140
Allowable welding current (A)	500		500

**POSITIONERS**  
 > 10 TONS PAYLOAD  
 available on request



POS250  
 positioner



Double axes dropcenter



Double axes L-shape

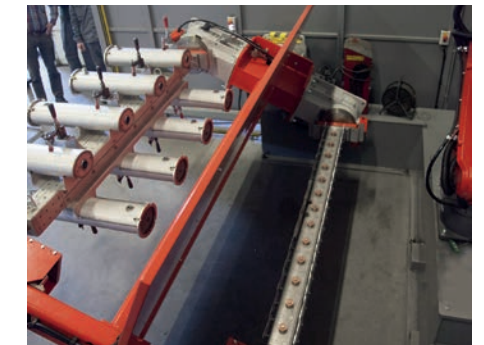

Triple axes Ferris Wheel

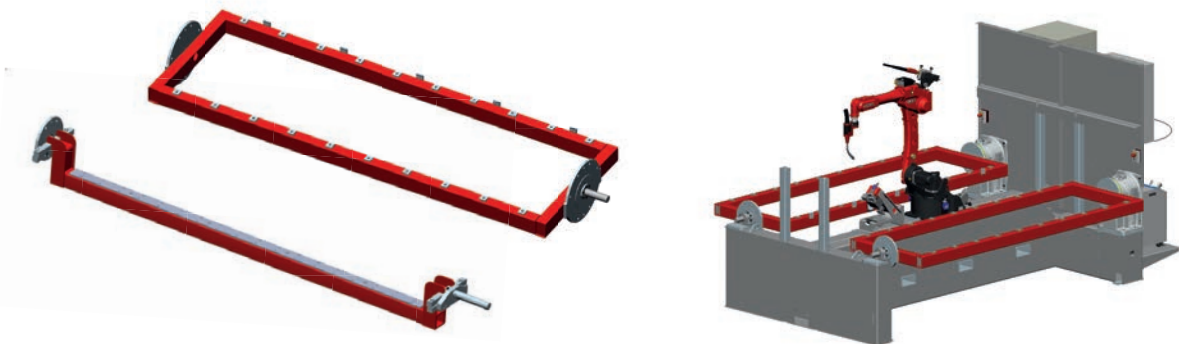

Positioner frames

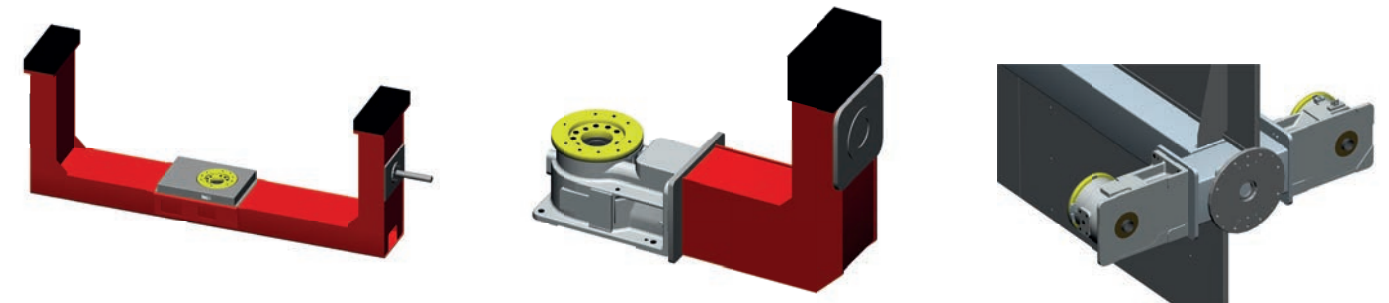



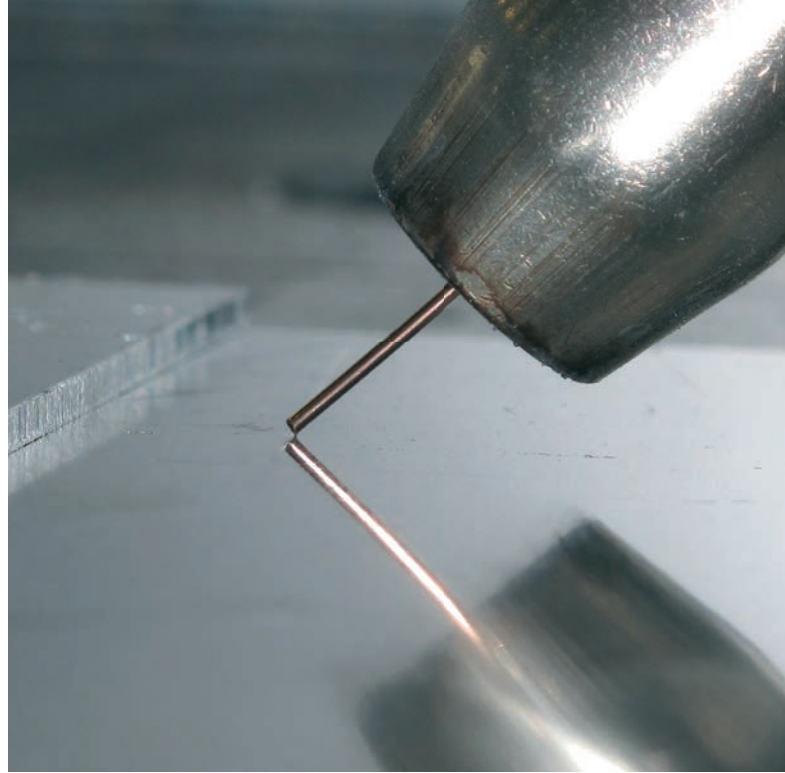

## Seam searching

### Sensors are needed if:

- The tolerances of the parts are not correct.
- The positioning of the parts is not correct.
- During the welding process distortion of the parts happens.
- Different versions of parts in one jig.

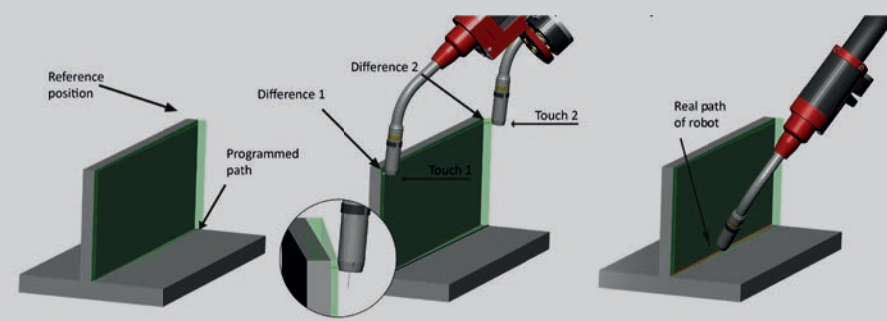

More information of Quick Touch sensing

### Touch sensing

- The system will perform a number of searching movements with the gas nozzle, before starting with welding.
- Standard searching with 120 V DC, safe upgrade to 300 V DC possible if needed.
- The robot calculates the shift and/or rotation in regards the original reference point within the program.
- Registration, limitation and monitoring of detected offset possible with optional software.

### Quick touch sensing (Wire searching)

- Same technology as touch sensing.
- Welding wire is the sensor.

- Much easier than using the gas nozzle.
- Precise measuring because of:
  - Clamping of the wire in the torch.
  - Cutting of the wire.
  - Opening of the feed rollers to avoid overcharge of the wire clamp.
  - The use of Transbase software from Panasonic.

### ARC-EYE DSS (Distance Spot Sensor)

- Find locations before welding with a laser spot.
- Same principle as touch sensing and Quick Touch.
- Developed and build by Valk Welding.
- Plug and play interface with **Panasonic** G3 controller.
- Measuring of position.

## Seam tracking

In addition to gas nozzle searching, wire searching (Quick Touch) and through the arc seam tracking, Valk Welding has developed the Arc-Eye welding seam tracking systems, which monitor the weld seams in real-time and automatically adjusts the programmed path of the robot. Adaptive welding in which the robot adjusts the welding parameters according to the seam geometry, is a plug and play upgrade compatible with the Arc-Eye CSS solution. The Arc-Eye system is developed for both reflective and non-reflective surfaces.

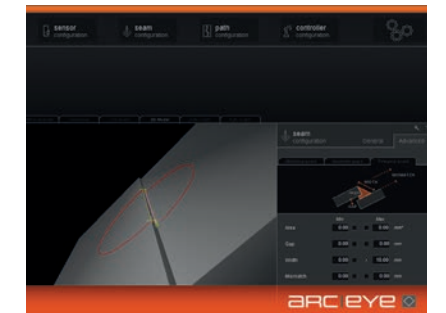
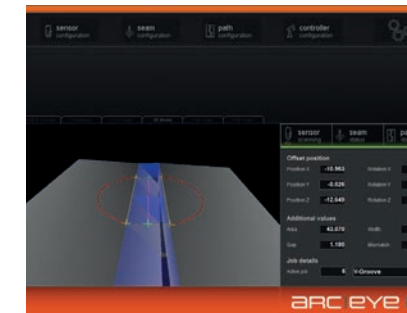
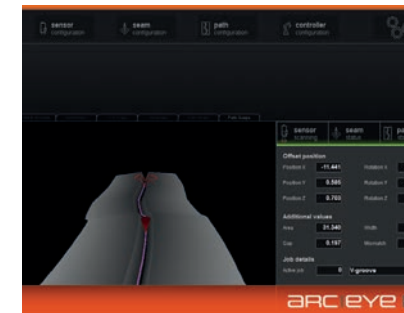

### ARC-EYE CSS

To check and adjust the position or the volume of the programmed path in the work piece, in addition to gas nozzle searching and wire searching (Quick Touch), Valk Welding has developed the Arc-Eye welding seam tracking systems, which monitors the weld seams real-time and adjusts automatically the programmed path of the robot. Adaptive welding in which the robot adjusts the welding parameters according to the seam geometry, is a plug and play upgrade compatible with the Arc-Eye CSS solution. The Arc-Eye system is developed for both reflective and non-reflective surfaces.

- Real-time seam tracking and spot sensing.
- 3D tracking with one scan thanks to patented circular scanning.
- Developed and build by Valk Welding.
- Plug and play interface as of **Panasonic** G3 controller.
- Measuring: position, orientation, geometry.
- For both reflective and non-reflective materials.
- Compatible with Valk Welding VWPR torch range and shock sensor.
- Perfect relation to the TCP of the robot.
- Resistant to dirt, heat and radiation.
- Important: safety class of the laser is 3R which means that there is no need for a laser controlled area and no further safety precautions for the laser are needed.

### Arc-Eye Adaptive Welding

The Arc-Eye CSS is upgradeable with the Arc-Eye Adaptive Welding function. With the Arc-Eye Adaptive laser the welding robot is not only able to follow the weld, but now also able to recognize the seam shape and automatically adjust the robot program accordingly. This creates an intelligent machine that detects and solves problems on its own.

More information of the Arc-Eye CSS solution



# Automation accessoires

As a technology partner, we continue to innovate and can increase the return on your investment with both standard extensions and unique solutions developed by Valk Welding.

Higher production-output by:

- Automatic Tungsten Exchange System (TEES).
- Automatic Torch Exchange System (TES).
- Automatic Arc-Eye Exchange System.
- Automatic Wire Exchange System (WES).
- Mechanical torch cleaner.
- Automatic Tip Exchange System

See most of these features in action

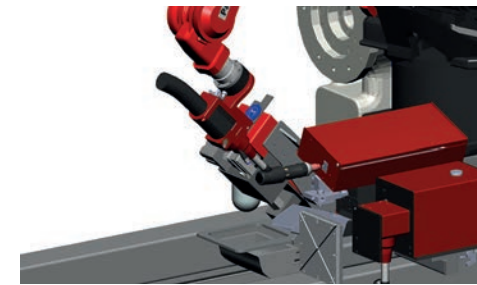

TEES - Tungsten Exchange System

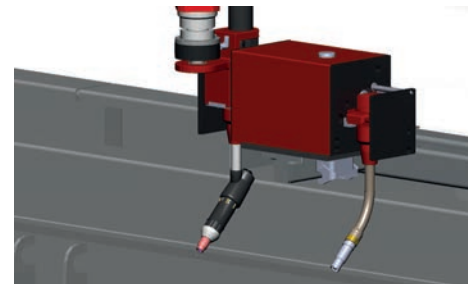

TES - Torch Exchange System

Arc-Eye Exchange System to increase automatically the accessibility of the robot where needed

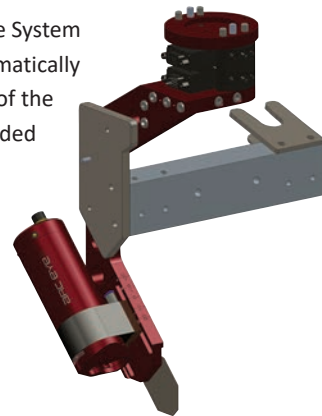

WES - Wire Exchange System to increase your productivity you can automatically swap between two different welding wires like steel and stainless steel, or two identical wires to automatically change from one drum to another when empty. And all of this with only one and the same cable assembly and welding torch. Just keep it simple.

Mechanical cleaner of the torch with reamer, anti-spatter nozzle and outside cleaner of the gas cup

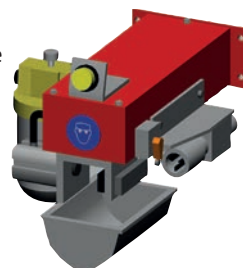

Tip Exchange System is a system for changing contact tips. This system is composed of a gas head removal and attachment system, a mechanical exchange magazine for ten contact tips, surveillance sensor and a rotary cleaning unit for contact tip cleaning.



# Safety

The safety of your employees is also of paramount importance to us. Each project is subjected in detail to a risk analysis which is part of the technical construction file. In short, the safety of your installation consists of:

- Zone protection if there is more than one workstation.
- One walk-in guard per station with start/stop/emergency stop control box and the mandatory 10 second release box.
- All necessary emergency stop buttons.
- Secure service doors if required.
- Fencing closed or in transparent version if possible.
- Welding fume extraction.



## People protection

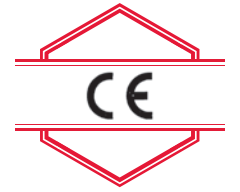
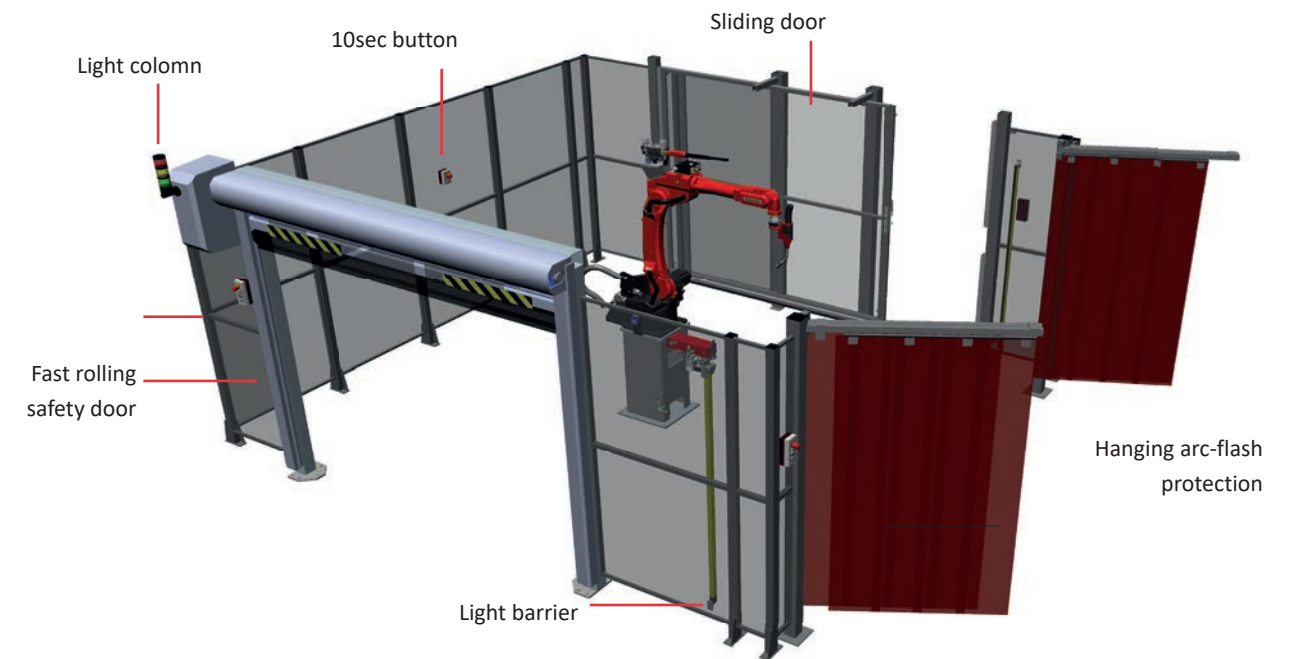

## Welding fume extraction

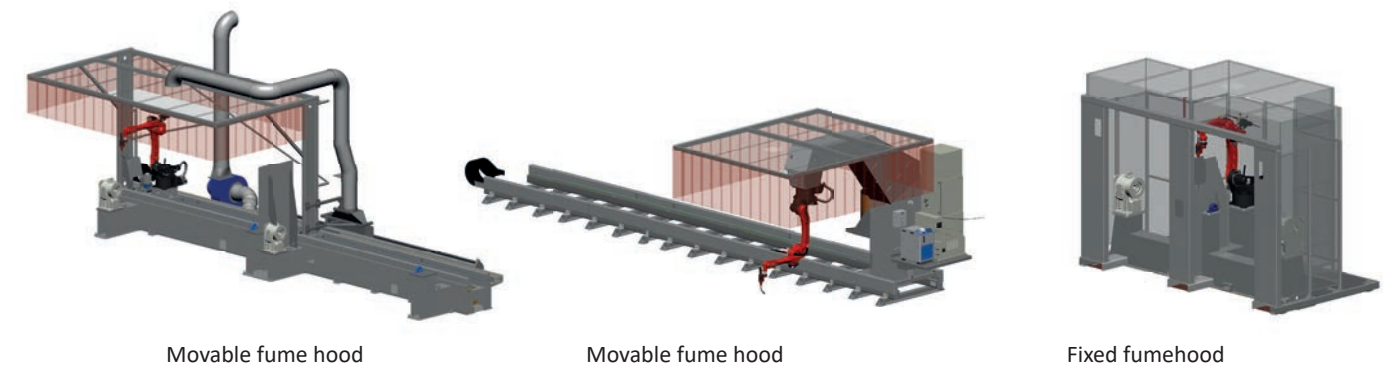



## Supporting software

Software is crucial for successful robot automatization. As your technical partner, Valk Welding is constantly developing the software to increase your productivity up to 10-30%.

Robot + Software: 1 + 1 = 3

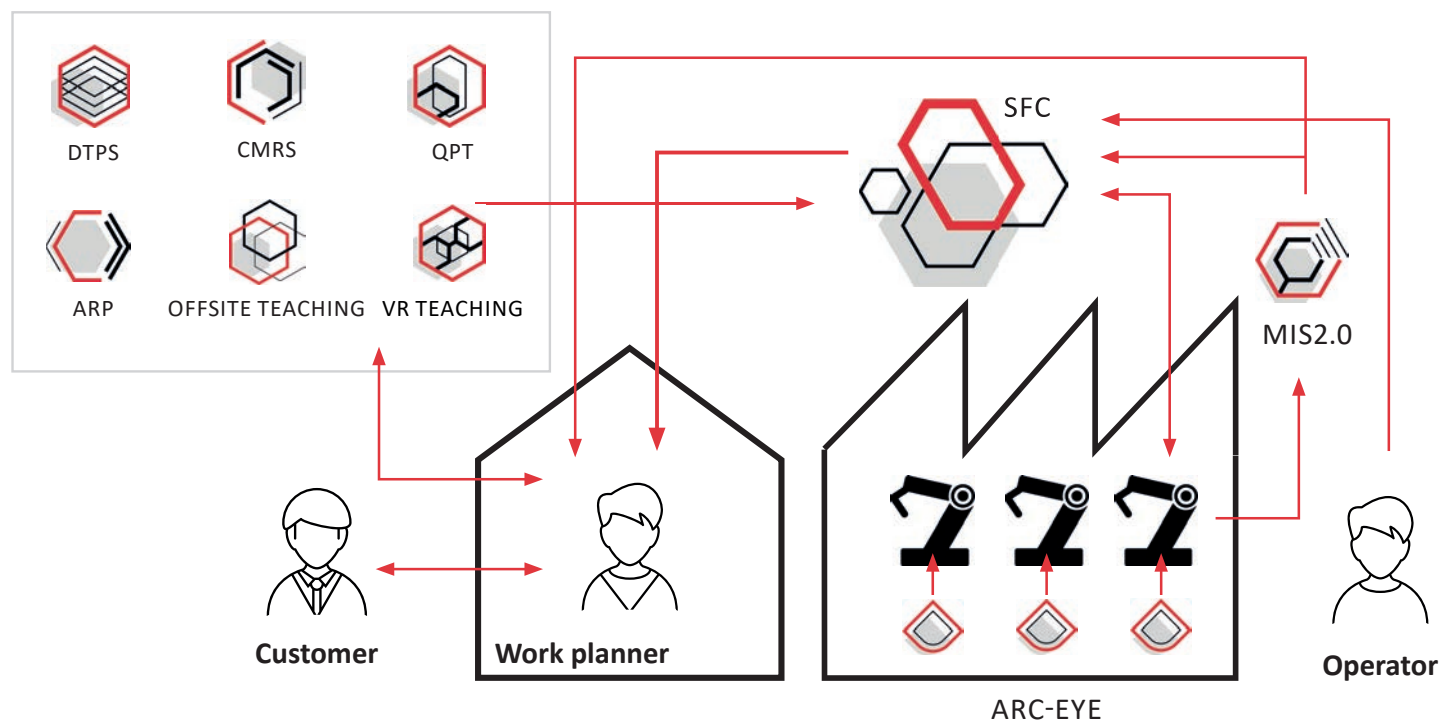

**DTPS:** Starting from your 3D CAD file of the work piece, you can program the robot(s) 100% offline without production downtime.



**CMRS:** Full automation of the programming by connection to your own database, simply by scanning a QR code. Our custom made solution for your needs.



**QPT:** With simple manual entering the product related information (for example dimensions) you can automate the programming to make Single piece production possible.



**ARP:** ARP is software for offline programming that reduces programming time. The programs are generated and simulated automatically. After that the programs are imported into DTPS and can be sent directly to the robot for production.



**OFFSITE TEACHING:** By moving a handheld torch in the

same way you weld around the part to be welded, you program your robot fast and easy, even without a CAD file of the part and jig.



**VR TEACHING:** Do you prefer manual programming but no production downtime? Then the virtual world offers a solution with our VR (Virtual Reality) Teaching development in combination with VR glasses.



**SFC:** Automatic organizing and controlling the robot(s) with the programs that have been created. Included chat functionality from the operators to the programmers.



**MIS2.0:** Recording and storing the relevant production data plus reporting via dashboards. Also full traceability is a feature of this solution.



**ARC-EYE:** Where needed welding seam tracking cameras to adjust the programs in real time to compensate for the deviations.



## Technical training

Operating and programming a robot is becoming increasingly simple, but both the beginner and the advanced robot user cannot do without (additional) training. In its Technical & Training Centers throughout Europe, Valk Welding therefore offers a very extensive number of robot and software training courses. All training is provided by skilled trainers on up-to-date robots.

- Advanced DTPS training

In the basic DTPS training you learn the capabilities of DTPS, the simulation function of DTPS, design a simple product. Basic programming instructions and how to create and customize a welding program and load it into the robot.

### Online training

For companies that start with welding robot automation, Valk Welding offers the following basic training modules.

- Basic training
- Maintenance and calibration
- Operator training
- Specials

Learn the basics of the robot, default settings, standard movements of the robot arm, service programs like cleaning and wire cutting. Welding parameters, principles of linear and circular oscillating welding. Learn the basics of the teach pendant and how to create and customize a welding program. After completing the basic training, employees are able to operate the welding robot independently.

### Offline training

For customers who have a license of DTPS, Valk Welding offers:

- Basic DTPS training

Due to the many possibilities of the DTPS package, extra knowledge about these possibilities may be desirable. Valk Welding therefore offers the "offline DTPS training for advanced users". During the training, the employees' issues will be dealt with and thus obstacles will be removed to develop into a professional DTPS user.

### Advanced training

For companies with experience in welding robot automation, Valk Welding offers the following advanced training modules:

- Thick plate training
- Macro / QPT training
- Arc-Eye training
- Welding training (best practice)
- MIS training
- SFC training

Valk Welding also offers training for older generation Panasonic robots. All generations of Panasonic robots are available for training purposes at the Dutch Technical Training Centre.



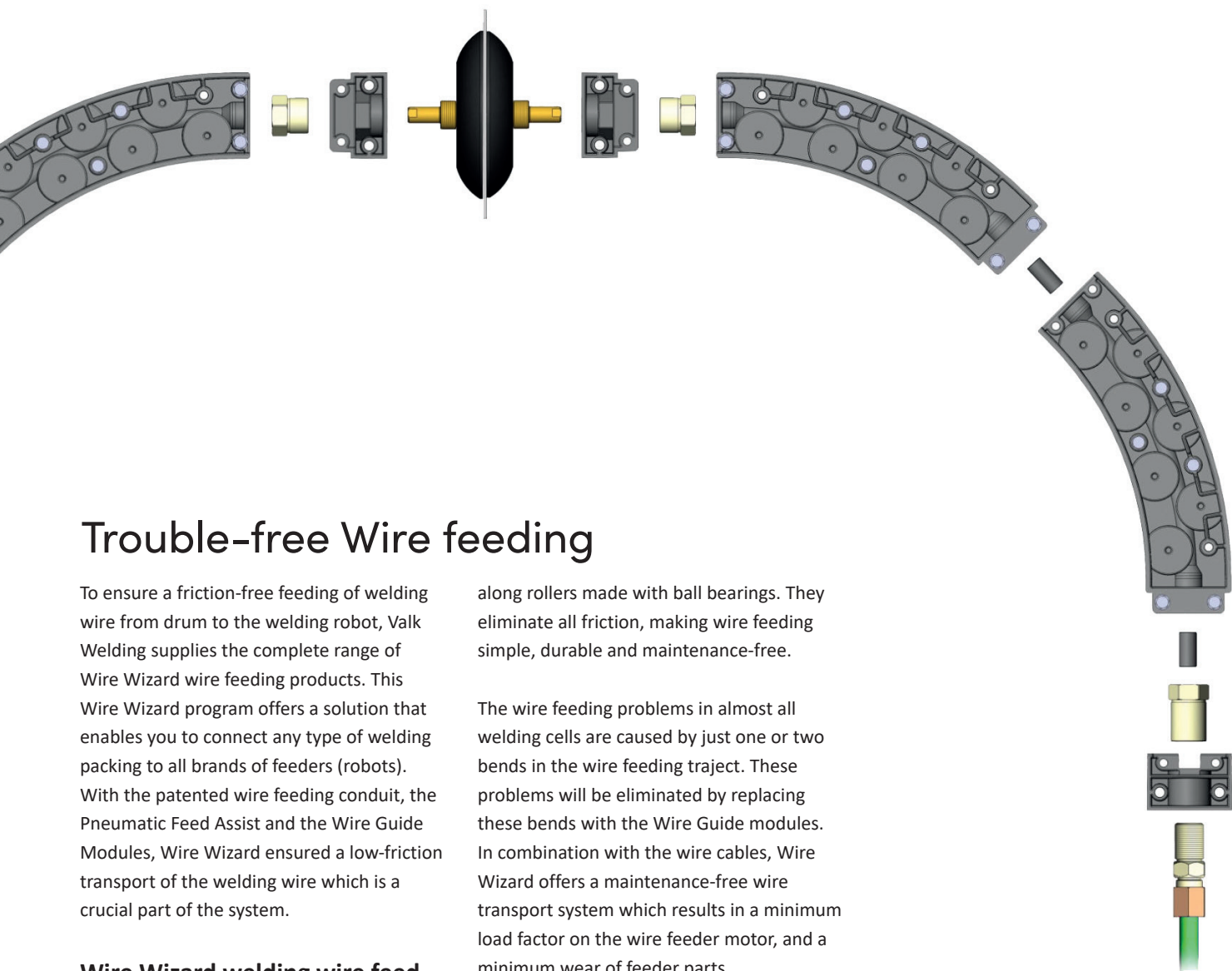

## Trouble-free Wire feeding

To ensure a friction-free feeding of welding wire from drum to the welding robot, Valk Welding supplies the complete range of Wire Wizard wire feeding products. This Wire Wizard program offers a solution that enables you to connect any type of welding packing to all brands of feeders (robots). With the patented wire feeding conduit, the Pneumatic Feed Assist and the Wire Guide Modules, Wire Wizard ensured a low-friction transport of the welding wire which is a crucial part of the system.

### Wire Wizard welding wire feed systems

Wire Wizard develops products for the flawless transport of welding wire from drum to contact tip, regardless of the brand of robot or type of drum or wire. There is a drumcone available for all drum types and connectors for every wire feeder in the market. High-quality conduits connect all the components and ensure low-friction transport of the welding wire.

### Friction-free through corners with Wire Guide Modules

Most of the friction in wire feeding comes from the bends and corners made with the wire conduit. That's why Wire Wizard has created a revolutionary product, the patented Wire Guide Modules. These wire guide modules guide the welding wire

along rollers made with ball bearings. They eliminate all friction, making wire feeding simple, durable and maintenance-free.

The wire feeding problems in almost all welding cells are caused by just one or two bends in the wire feeding trajectory. These problems will be eliminated by replacing these bends with the Wire Guide modules. In combination with the wire cables, Wire Wizard offers a maintenance-free wire transport system which results in a minimum load factor on the wire feeder motor, and a minimum wear of feeder parts.

### friction-free wire transport over larger distances

The large weight of a drum of welding wire makes it preferable to place it outside the robot cell at an easy accessible place. In the case of a large robot system, this means that the welding wire must be able to bridge a longer distance. Wire Wizard's Pneumatic Feed Assist (PFA) is a simple solution to feeding welding wire to the robot over longer distances, up to 50 meters!!

- PFA works completely independently and can be added to any existing system
- Welding wire drums can therefore be placed on locations which are more easily accessible

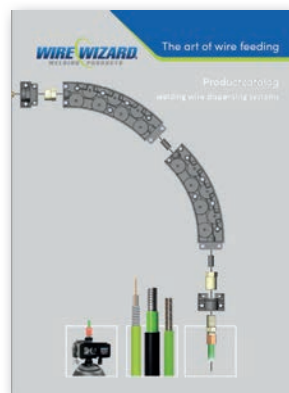

The comprehensive product catalog helps you step-by-step to achieve the correct configuration. Available as a download at [www.wire-wizard.eu](http://www.wire-wizard.eu) or by request at [sales@wire-wizard.eu](mailto:sales@wire-wizard.eu)



How can we serve you?



# The strong connection



Valk Welding NL  
Staalindustrieweg 15  
Postbus 60  
2950 AB Alblasterdam  
Tel. +31 78 69 170 11

Valk Welding BE  
Tel. +32 3 685 14 77

Valk Welding FR  
Tél. +33 3 44 09 08 52

Valk Welding DK  
Tel. +45 64 42 12 01

Valk Welding CZ  
Tel. +420 556 73 0954

Valk Welding DE  
Tel. +49 152 29 109 708

Valk Welding PL  
Tel. +48 696 100 686

Valk Welding SE  
Tel. +46 510 48 88 80

Valk Welding IE  
Tel. +31 78 69 170 11

[info@valkwelding.com](mailto:info@valkwelding.com)  
[www.valkwelding.com](http://www.valkwelding.com)