

Catalog

ROBOTIC WELDING
TORCHES

2023

EDR



EDR torches[®]
Evolution Design Robotics

ROBOTIC WELDING TORCHES



We are present worldwide

EDRtorches, S.L.
Calle Miguel Angel Blanco 28. 46138 -
Rafelbuñol - Valencia Spain.
www.edrtorches.com
info@edrtorches.com
Tel. 0034 963 558 893

Company

“We understand that the development of a product starts at the design stage but just as important are quality and production”

Companies with technological or industrial character know the importance of innovating to continue in the current market. In EDR torches this becomes a work philosophy, we understand that without innovation it is not possible to advance in such a competitive world where companies and professionals need increasingly complex solutions.

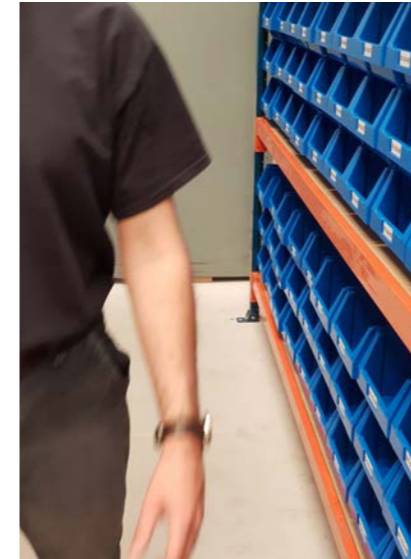

EDR torches has a strong R & D department dedicated to the development of new welding applications, providing customized solutions both in the area of robotic welding and manual.

We understand that the development of a product begins at the design stage but just as important are the quality and production designed and tested.

The long experience of EDR torches in all sectors related to welding makes us capable of providing the best solutions to your manufacturing challenges, tell us what you need and we will make it possible.

R&D

“EDRtorches is the result of a long engineering work developing products for robotic welding system”

When we gather in a company more than 20 years of experience in designing applications and solutions in welding, with a high level engineering team only something good can arise, EDRtorches is the result of a long engineering work developing products for welding systems robotic, automated and manual.



Our spirit of continuous innovation is evident in the entire product line we manufacture, we believe that we must see beyond what the industry needs and anticipate solutions to future challenges.

With the product ranges endorsed by companies worldwide, we ensure the most appropriate solution to your demand, in addition to a high level of advice.

EDRtorches we have the solution and the product you need.



Index

Systems and technical advantages BOT series

Models of the BOT range 6 Pag.

Description of advantages 9 Pag.

Robotic welding torches

1 MIG / MAG welding necks 16 Pag.

1 TIG welding 30 Pag.

2 Power cable systems MIG / MAG 32 Pag.

3 Anti-collision systems MIG / MAG 40 Pag.

4 Discs of adaptation to robots 46 Pag.

5 Peripheals 50 Pag.

6 Protective liquids 58 Pag.

7 Selection guides BOT installations 60 Pag.



MIG/MAG BOT

TIG BOT



iBOT

System for robots with hollow wrist shaft and internal wiring to axis 6.

eBOT

System for standard robots with closed wrist and external wiring to axis 6.

coBOT

Systems with the necessary features to use in collaborative robots, you can also use eBOT systems by removing the anti-collision module

etBOT

TIG system for industrial robots with external axes with anti-collision system and supply of

ctBOT

TIG system for collaborative robots with cold wire supply

Depending on the type of robot to use, we need to select a system that adapts to the robot, for this there are three systems available for the two types of robots that exist in the market. Hollow shaft systems where we will adapt the iBOT, external wiring system where we will adapt eBOT or the cBOT if we want our system to work at high speed in its movements.

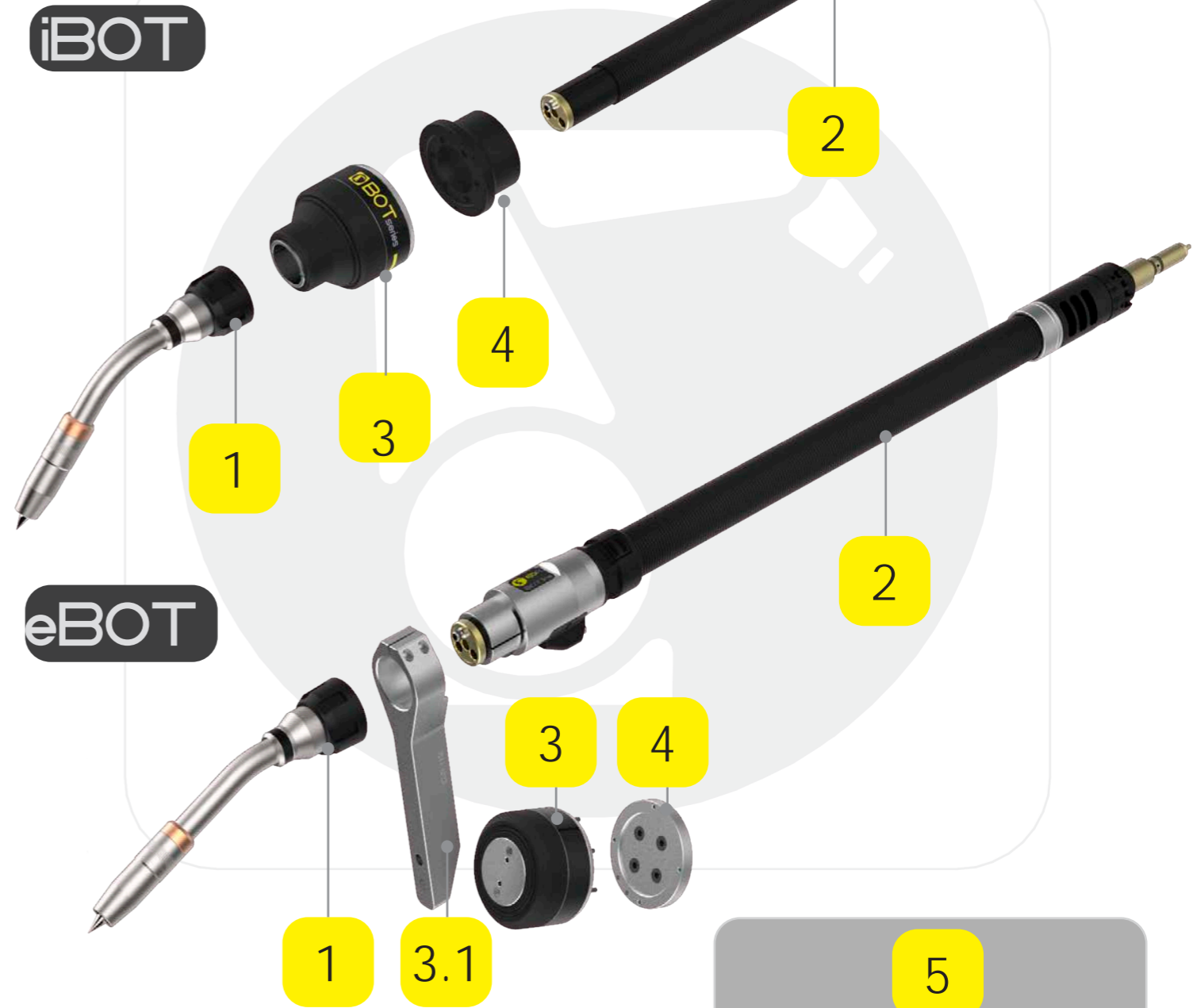

- 1- Torch necks.
- 2- Power cables.
- 3- Anti-collision systems
- 4- Discs adapters for robots.
- 5- Accessories torches.

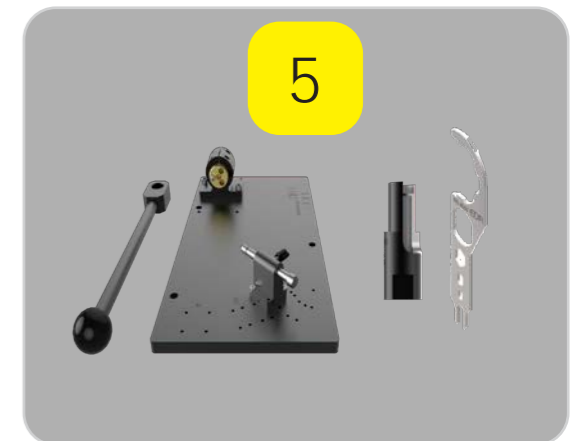

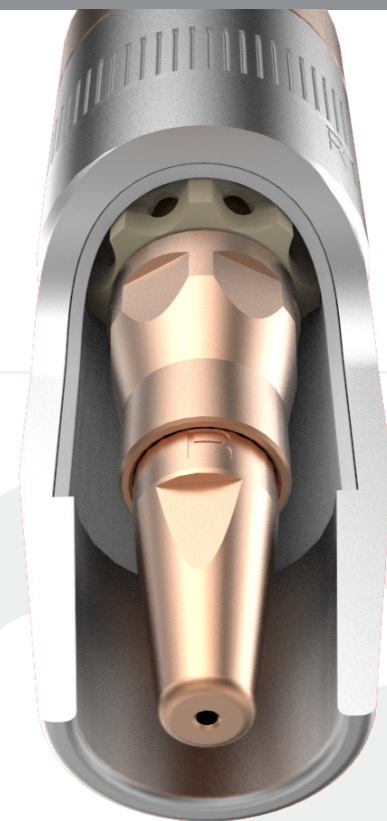

COLD Tip

Exclusive system for cooling contact tips, reduces heating of the contact tip by 50%, extending the tip duration up to 4 times.

EASY Cleaning

Comprehensive cleaning mechanism for welding projections, developed for the automotive industry where the projections are very high, this system eliminates the projections of the interior of the nozzle completely in each cleaning cycle. Recommended in applications where the level of projections is very high.

FOUR Power

The 4 power conductors designed for high levels of torsion and high resistance to fatigue, provide that the torch system never stops working by the breakage of one or several cables, in addition to multiply by two the section of the cooling flow.

CEROFit

The high precision machining performed in the same manufacturing phase, the anti-collision adjustment systems are manufactured in the same machining sequence with maximum precision.



All the necks of the BOT range are INTERCHANGEABLE AND COMPATIBLE, it is only necessary to distinguish between gas or liquid refrigerated systems. A wide range of collars is available. Check if special execution is desired.

The BOT collar system of the modular package is interchangeable and compatible with all torch lines iBOT, eBOT and cBOT, besides all the powers of neck have the same TCP.

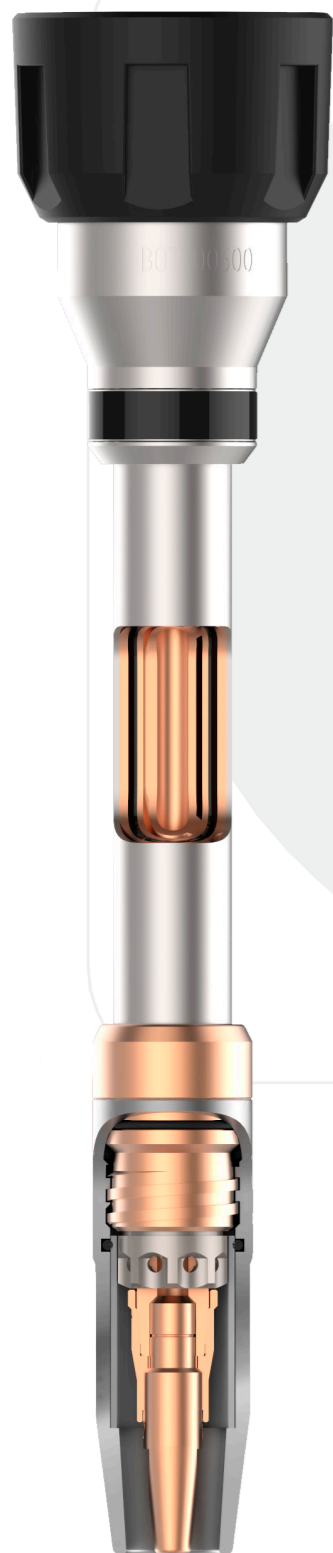

1°- Total compatibility and wide range of torch collars. Threaded neck change system, quick and easy with independent circuits and automatic liquid shutoff valves



2°-Swap system interchangeable in the neck, this system makes the tow remains stable on the contact point when the torch is in motion.



3°-Clamping nut with key-way slots prevents bad contacts where the neck can be loosened, this is optional because the neck is perfectly held by the force of the hand.



4°-Double circuit cooling system for nozzle and contact tip completely Independent. Gas driving totally separates from the rest of circuits like the thread of contribution, improving the stability of the gas outlet and the projection.

5°-Structure of the neck in stainless steel, gives a rigidity and stability of the TCP much higher than the termination in Brass more unstable with changes in temperature

6°-Extra-hard copper-cobalt alloy nozzle holder, this alloy provides high thermal cooling and a hardness far superior to brass and other copper, with less wear of the neck rock and ° longer duration before being replaced.

7°-O-ring retention, high temperature seal that prevents the nozzle from loosening and eliminates any loss of gas that occurs in the threads.

8°-Electrical insulation of the interchangeable nozzle, the new interchangeable insulator reduces the consumables expense by not having to re-

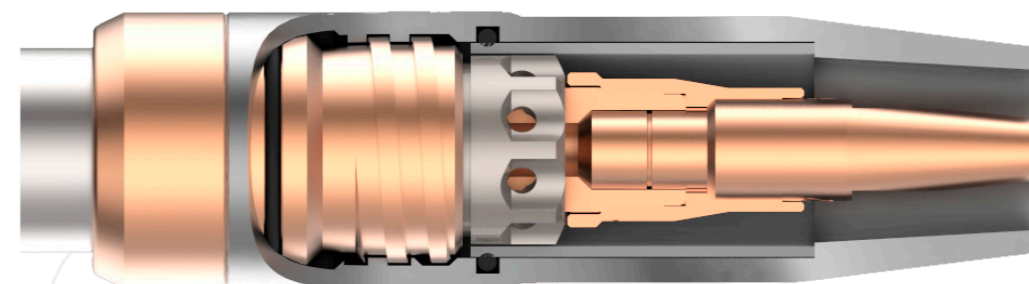

COLD Tip

9°-Long duration tip system COLD Tip, exclusive of the BOT torch line, with this system the use of standard system contact tips is reduced from 3 to 5 times, in addition to the loss of time with the change. How is it achieved. The system maintains the tip of contact at low temperature which makes the hardness of copper is not affected and wear less with the passage of the thread, in addition to stay cold the projections do not stick. Half of the contact tip enters a cooling chamber, The cone of the tip gives electrical and thermal transmission efficiency.

41EC necks with integral cleaning

System that achieves the total elimination of projections, this is especially useful in welding galvanized steels used in the automotive industry where Zinc generates large projections that make cleaning difficult and produce multiple breakdowns.

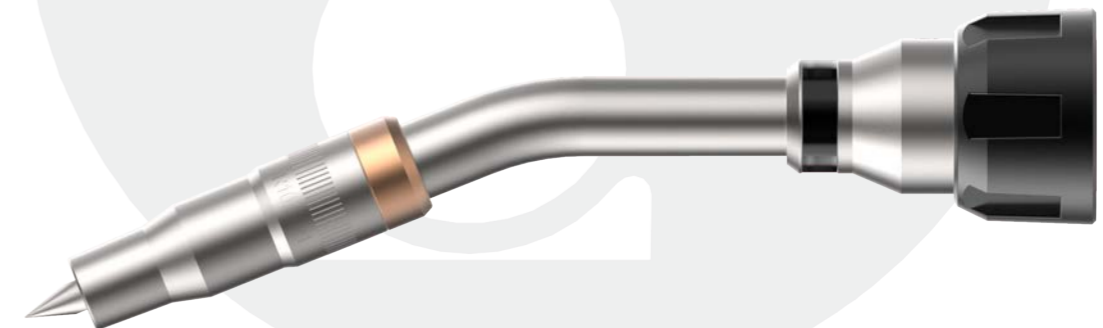

Its special diffuser makes the gas circulate externally facilitating and cleaning through the external channeling of holes. This improves the cooling of the nozzle, facilitates cleaning and prevents the accumulation of projections. This integral cleaning system allows the total elimination of the projections accumulated in the spare part. Your special cleaning cutter adapts to the shape of the spare by eliminating the gaps where the projections accumulate and increasing the duration of the spare part and the stops.

EASY Cleaning

The TIG welding system for BOT systems can be used with or without thread supply, it is liquid cooled and its cooling power allows high working cycles maintaining the stability of tungsten.

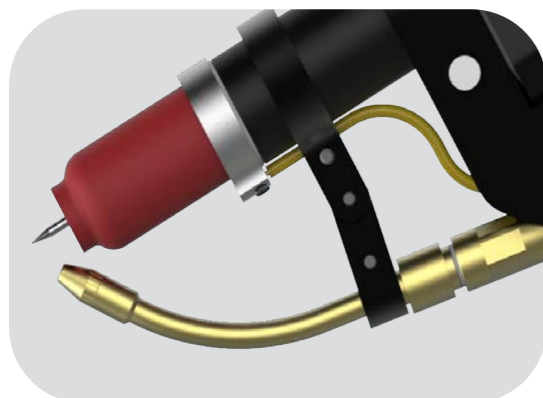

- 1°-Angle adjustable cold wire guide.
- 2° Integrated HF priming improvement ring
- 3°-Oversized tungsten holder, with built-in guide system, keeps the tungsten cooled and centered.

BOT torch systems are designed with special materials that withstand high mechanical stresses and strong dynamic movements, thus preventing the breakage of their components by fatigue. The torch cable assembly is quick and easy, without the need for any special tools. Each type of robot determines a length of torch cable, we have all the measures to cover all possibilities. Cables for collars cooled by gas and water are available.



1°-Valves of automatic closing of the cooling circuit, allows to make a quick change of neck without loss of liquid and without the need to stop the cooling group.



2°-Nozzle sensor (optional), allows contact detection with the nozzle for multiple applications.



3°-Four special power cables FOURPower (liquid cooling system), allow a duration and an extra cooling capacity, in addition the materials of the power cables are prepared to rotate 360 in both directions which gives a freedom of 720° turn of the largest for these systems.

- Exterior of the PA housing supports high temperatures without wear with more than 1 million cycles of fatigue at break.
- Copper conductors with tin coating to prevent wear by electrolysis, this increases the break time up to 5 times.



4°-Multi-connector adaptation system, the energy package allows to easily change the type of connector to adapt to any type of machine, from the most standard to special connectors under design.



Euro type



Miller type



Panasonic type

3

Anti-collision system

The BOT anti-collision sensor is intended for the deactivation of the robot in case of accidental collision of the welding gun.

This sensor consists of a Rocker system that detects the collision in any direction of movement, returning to its initial position when the obstacle that caused the collision disappears.

The resistance of the sensor is prepared to protect the torch system at low speed, at high speeds total protection is not guaranteed.

- 1°-Rubber protection for high temperature and IP63 sealing, protects the sensors and all the fixing screws.
- 2°-Internal system of 6 points of support avoids dead zones of low resistance to movement.
- 3°-Machining of interlocking systems CEROFit. Machined parts in the same sequence provide zero differences in their tolerance giving superior precision.
- 4°-Three independent sensors provide protection in all directions and high urity.

iBOT

eBOT



3.1 Clamping flange torches eBOT

Only eBOT

- Flange of zero degrees, for necks 45°.
- Flange of 23 degrees, for necks 22°.

RETROFIT

Customizable designs to adapt the new torches of the BOT series to the old TCP of your old torch, thus

Flanges of different sizes adaptable to different TCP systems. your old torch, thus



4

Disc adapter to robots

The systems of adaptation to industrial robots, the way to incorporate the torches BOT to any type of industrial robot, there are industrial robots specific for welding that are the standard collected in the references but it is also possible to make larger diameter adaptation discs for robots of other types of applications. The measurements correspond to the centers of the fixings of the dolls of the robot, to identify the code to check the robot model or to request information to the technical service

iBOT

eBOT

COBOT

- Adaptation discs for iBOT series hollow shaft robot systems
- Adaptation discs for eBOT series external wiring robot systems
- Adapters for external shaft robots and collaborative robots for torches type BASIC

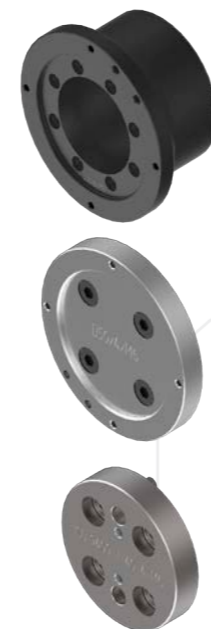

5

Accessories for the BOT line

Plates of verification and rectification of the TCP for the welding necks, guarantee the correct repetitiveness of the welding necks. guarantee the correct repetitiveness of the welding necks.

Automatic cleaning station for robotic welding systems.

Accessories related to the maintenance and cleaning of spare parts of the robotic welding torch.



MIG / MAG Welding necks

1

Robotic welding collars MIG / MAG gas cooling.

BOT-30G (300A) 18 Pag.

Robotic welding collars MIG / MAG liquid cooling.

BOT-31W (350A) 20 Pag.

BOT-41EC (400A) 22 Pag.

BOT-40W (500A) 24 Pag.

BOT-50W (550A) 26 Pag.

BOT-60W (600A) 28 Pag.

Robotic welding necks TIG liquid cooling.

BOT-T5W (400A) 30 Pag.





Welding process:
MIG/MAG, GMAW, 131,135
Technical data according to IEC60974-7



Gas



300 A - CO2 100%



250 A - Mix M21 (ISO 14175) 100%



Ø1.0-1.2 mm



10-18 l/min

The capacity will be reduced by 35% with pulsed arc.

MIG / MAG neck model for applications with medium work intensity, adaptable to a multitude of robotic and automatic applications, powerful model without the need to use a cooling unit, simplifying maintenance.

The welding systems for industrial robots BOTseries are designed for work cycles of 24 hours, developed for an intensive use, precise and specifically adapted to long work cycles.

STANDARD CONFIGURATION

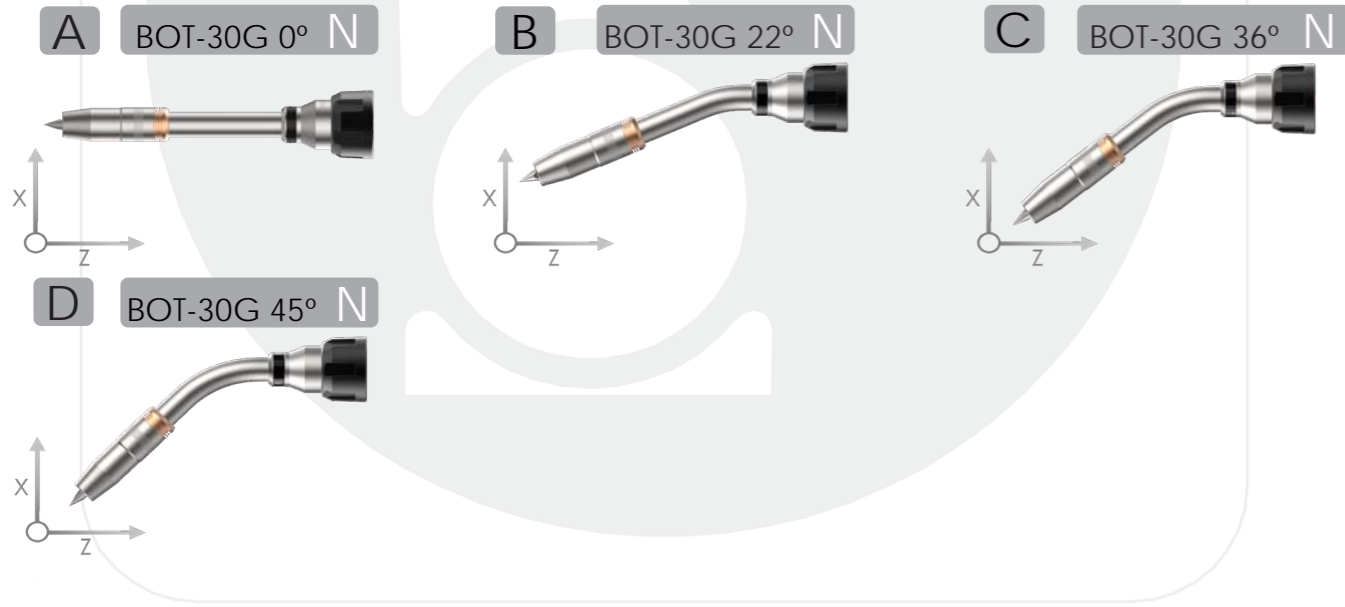

*Put S at the end of the code for model with nozzle sensor.
example R12 0220 S

Pos.	TYPE	CODE	Min. Q.
A	Torch neck BOT-30G 0° (X=0 mm, Z=259 mm)-long type N	R12 0000	1
B	Torch neck BOT-30G 22° (X=64 mm, Z=247 mm)-long type N	R12 0220	1
C	Torch neck BOT-30G 36° (X=96 mm, Z=230 mm)-long type N	R12 0360	1
D	Torch neck BOT-30G 45° (X=111 mm, Z=217 mm)-long type N	R12 0450	1

SPARE PARTS

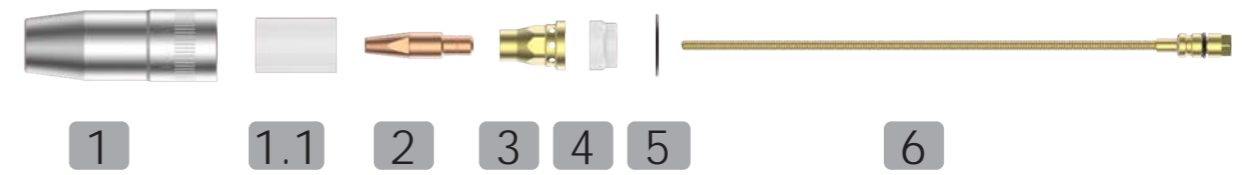

Pos.	TYPE	CODE	Min. Q.
1	Nozzle L76xØ15.5 mm	R10 0011	2
	Nozzle L76xØ13 mm	R10 0012	2
	Nozzle L79xØ15.5 mm	R10 00211	2
1.1	Insulator nozzle L35XØ19.5 mm	R10 0002	2
2	Contact tip M10 1.0 mm Cu-BICOMP	R10 0400 10	5
	Contact tip M10 1.2 mm Cu-BICOMP	R10 0400 12	5
	Contact tip M10 1.6 mm Cu-BICOMP	R10 0400 16	5
	Contact tip M10 0.8 mm CuCrZr	R10 0401 08	10
	Contact tip M10 1.0 mm CuCrZr	R10 0401 10	10
	Contact tip M10 1.2 mm CuCrZr	R10 0401 12	10
3	Contact tip M10 1.6 mm CuCrZr	R10 0401 16	10
	Diffuser L26xØ18.5 mm M10	R12 0013	2
	Insulator neck L11XØ18.5 mm	R12 0308	2
5	Oring neck Ø23 mm	R10 0401	10



Pos.	TYPE	CODE	Min. Q.
9	Tip TCP M10-15mm programming	R10 0115	1
10	Neck tool BOT	R04 0000	1
11	Clining reamer TH L26xØ15x10.5mm	R03 2040	1

STANDARD MEASURES

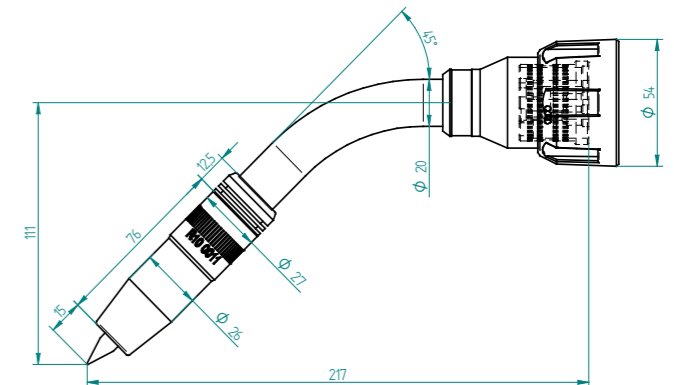



Welding process:
MIG/MAG, GMAW, 131,135
Technical data according to IEC60974-7



Liquid



350 A - CO2 100%



300 A - Mix M21 (ISO 14175) 100%



Ø 0.8-1.2 mm



10-16 l/min

The capacity will be reduced by 35% with pulsed arc.

MIG / MAG neck model for places of difficult access, medium work intensity and adaptable to many robotic applications, short spare model to facilitate welding in narrow places.

The welding systems for industrial robots BOTseries are designed for work cycles of 24 hours, developed for an intensive use, precise and specifically adapted to long work cycles.

STANDARD CONFIGURATION

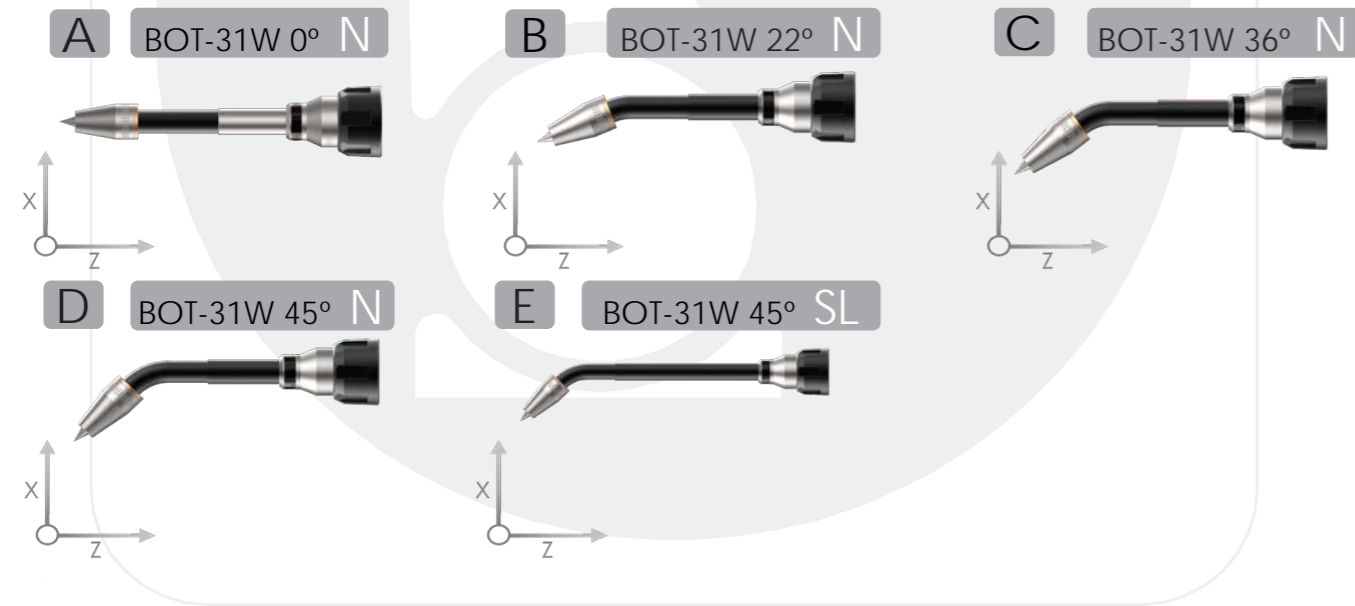

*Put S at the end of the code for model with nozzle sensor.
example R12 0220 S

Pos.	TYPE	CODE	Min. Q.
A	Torch neck BOT-31W 0° (X=0 mm, Z=243 mm)-long type N	R13 1000	1
B	Torch neck BOT-31W 22° (X=26 mm, Z=236 mm)-long type N	R13 1220	1
C	Torch neck BOT-31W 36° (X=44 mm, Z=227 mm)-long type N	R13 1360	1
D	Torch neck BOT-31W 45° (X=56 mm, Z=219 mm)-long type N	R13 1450	1
E	Torch neck BOT-31W 45°L (X=56 mm, Z=319 mm)-long type SL	R13 1451	1

en-DSBOT31W-02

SPARE PARTS



Pos.	TYPE	CODE	Min. Q.
1	Nozzle L47xØ13.5 mm	R10 0301	2
2	Contact tip M6 0.8 mm CuCrZr	R10 0200 08	10
	Contact tip M6 1.0 mm CuCrZr	R10 0200 10	10
	Contact tip M6 1.2 mm CuCrZr	R10 0200 12	10
3	Diffuser Insulator neck L19XØ18 mm	R12 0314	2
4	Tip holder L20xM12 mm M6	R10 2103	2
5	Oring neck Ø23 mm	R10 0401	10
6	Liner for neck type N 217mm	R10 1112	1
	Liner for neck type SL 317mm	R10 1114	1
7	Oring neck water Ø9 mm	R12 0008	10



Pos.	TYPE	CODE	Min. Q.
9	Tip TCP M6-12 mm programming	R10 0312	1
10	Neck tool BOT	R04 0000	1
11	Clining reamer TH L23xØ13x8.5mm	R03 2030	1

STANDARD MEASURES

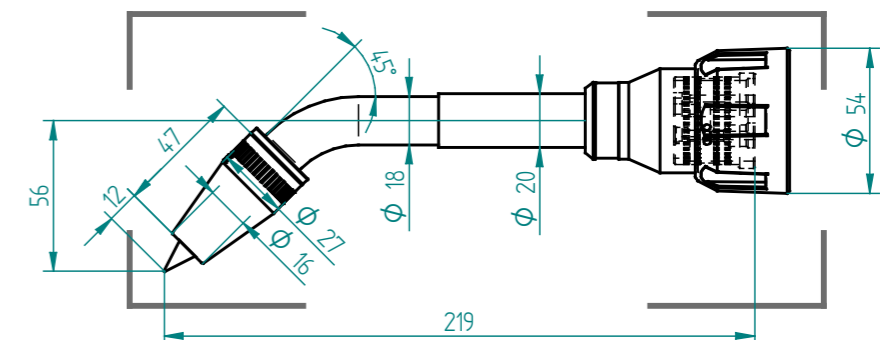



EASY cleaning

MIG / MAG neck model specially designed for applications with high number of projections, welding of galvanized steels or positions that facilitate the projections to cumulate, medium-high working capacity and adaptable to a multitude of robotic applications, recommended model in welding for the automation

The welding systems for industrial robots BOTseries are designed for work cycles of 24 hours, developed for an intensive use, precise and specifically adapted to long work cycles.



Welding process:
MIG/MAG, GMAW, 131,135
Technical data according to IEC60974-7



Liquid

400 A - CO2 100%

350 A - Mix M21 (ISO 14175) 100%

Ø 1.0-1.2 mm

10-16 l/min

The capacity will be reduced by 35% whit pulsed arc.

STANDARD CONFIGURATION

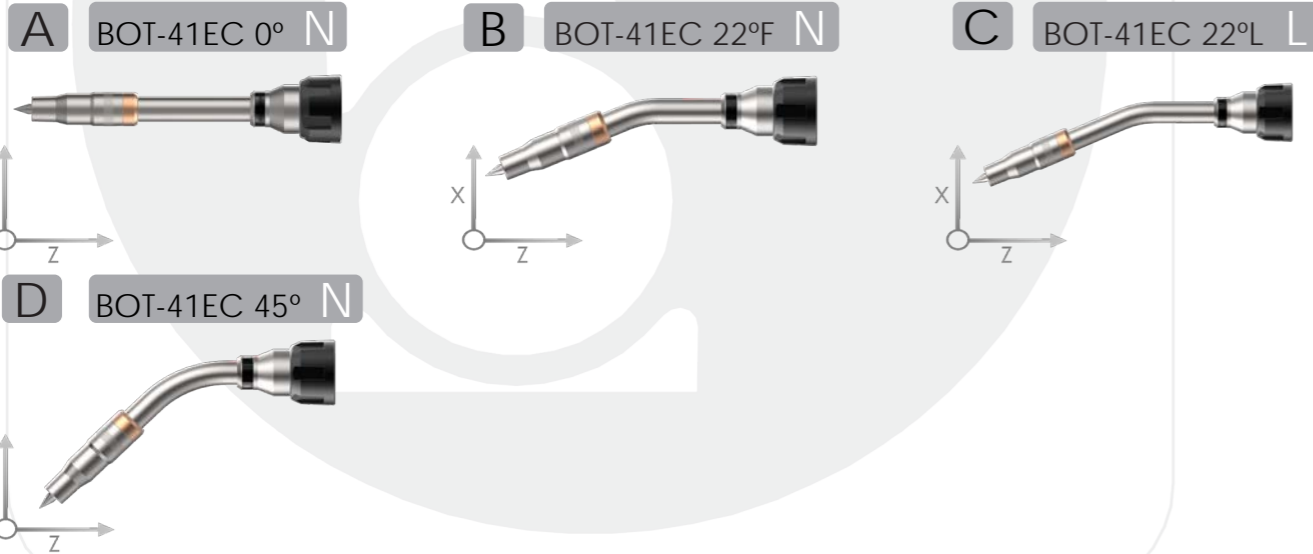

*Put S at the end of the code for model with nozzle sensor.
example R12 0220 S

Pos.	TYPE	CODE	Min. Q.
A	Torch neck BOT-41EC 0° (X=0 mm, Z=259 mm)-long type N	R14 1000	1
B	Torch neck BOT-41EC 22°F (X=50 mm, Z=250 mm)-long type N	R14 1220	1
C	Torch neck BOT-41EC 22°L (X=65 mm, Z=297 mm)-long type L	R14 1221	1
D	Torch neck BOT-41EC 45° (X=111 mm, Z=217 mm)-long type N	R14 1450	1

esDS-BOT41EC-02

SPARE PARTS

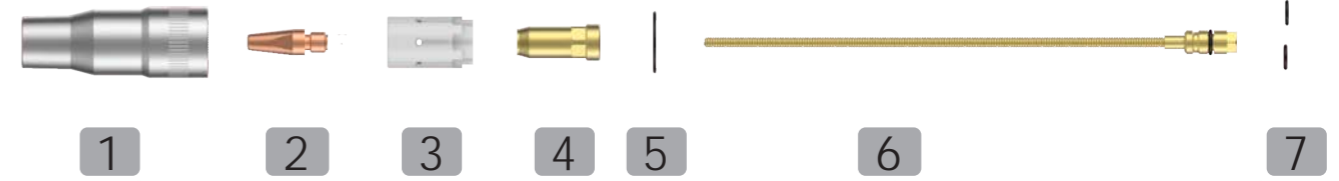

Pos.	TYPE	CODE	Min. Q.
1	Nozzle EC L76xØ15.5 mm	R10 0021	2
2	Contact tip M8 1.0 mm Cu-BICOMP	R10 0300 10	10
	Contact tip M8 1.2 mm Cu-BICOMP	R10 0301 12	10
3	Diffuser Insulator nozzle L35XØ19.5	R12 0414	2
4	Tip holder L34 mm M8xM14	R10 0014	2
5	Oring neck Ø23 mm	R10 0401	2
6	Liner for neck type N 217mm	R10 1112	1
	Liner for neck type L 267mm	R10 1113	1
7	Oring neck water Ø9 mm	R12 0008	10



Pos.	TYPE	CODE	Min. Q.
9	Tip TCP EC M8-15mm programming	R10 0215	1
10	Neck tool BOT	R04 0000	1
11	Clining reamer EC-TH L38.5xØ15x10.5mm	R03 2010	1

STANDARD MEASURES

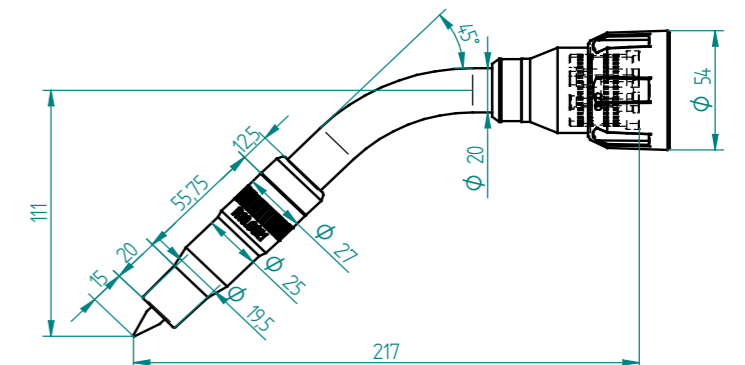



Welding process:
MIG/MAG, GMAW, 131,135
Technical data according to IEC60974-7



Liquid



500 A - CO2 100%



400 A - Mix M21 (ISO 14175) 100%



Ø 1.0-1.6 mm



10-18 l/min

The capacity will be reduced by 35% with pulsed arc.

MIG / MAG neck model with high versatility, very versatile for medium-high work intensity and adaptable to a multitude of robotic and automatic applications, one of the most versatile models.

The welding systems for industrial robots BOTseries are designed for work cycles of 24 hours, developed for an intensive use, precise and specifically adapted to long work cycles.

STANDARD CONFIGURATION

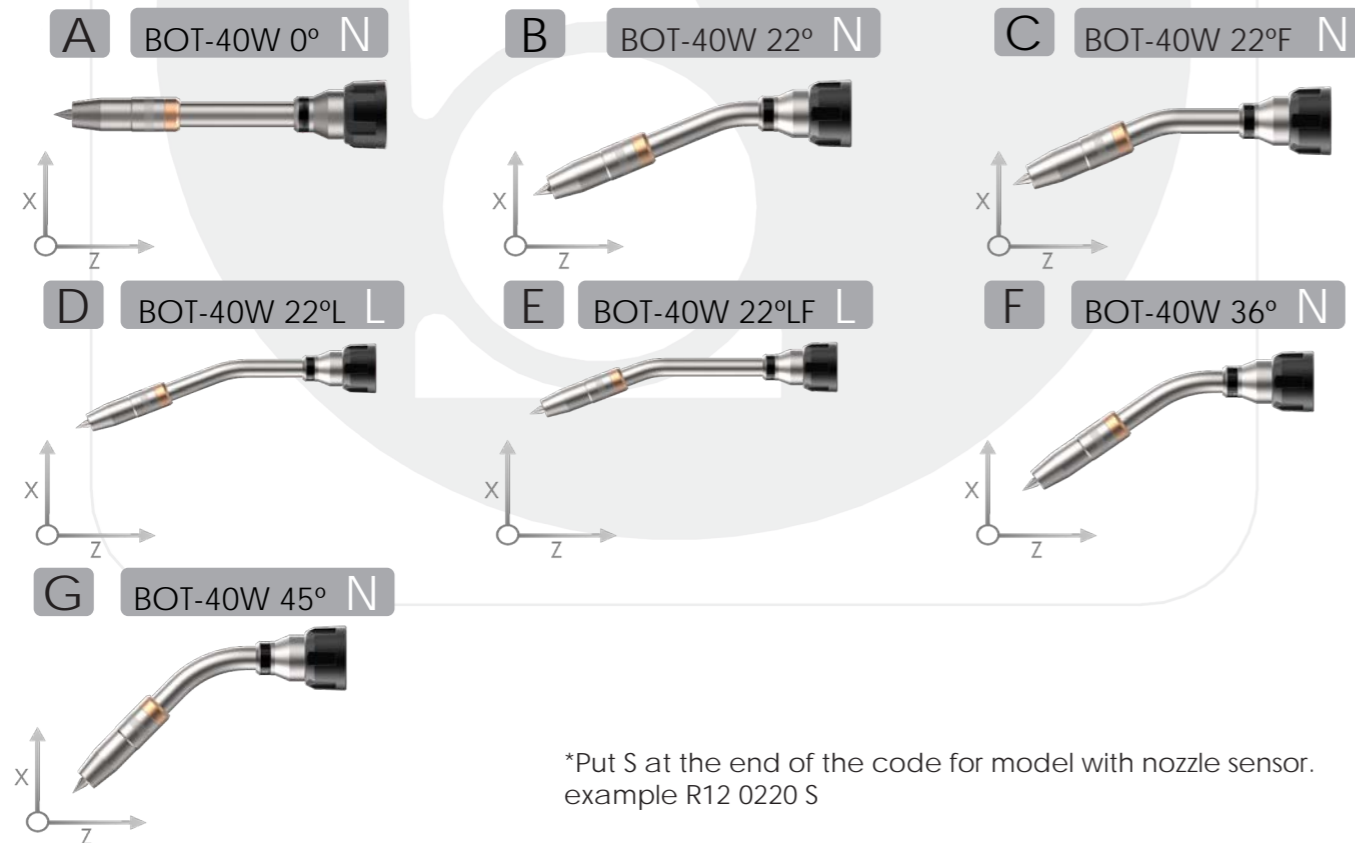

Pos.	TYPE	CODE	Min. Q.
A	Torch neck BOT-40W 0° (X=0 mm, Z=259 mm)-long type N	R14 0000	1
B	Torch neck BOT-40W 22° (X=64 mm, Z=247 mm)-long type N	R14 0220	1
C	Torch neck BOT-40W 22°F (X=50 mm, Z=250 mm)-long type N	R14 0222	1
D	Torch neck BOT-40W 22°L (X=64 mm, Z=297 mm)-long type L	R14 0221	1
E	Torch neck BOT-40W 22°LF (X=50 mm, Z=300 mm)-long type L	R14 0223	1
F	Torch neck BOT-40W 36° (X=96 mm, Z=230 mm)-long type N	R14 0360	1
G	Torch neck BOT-40W 45° (X=111 mm, Z=217 mm)-long type N	R14 0450	1

enDS-BOT40W-02

SPARE PARTS

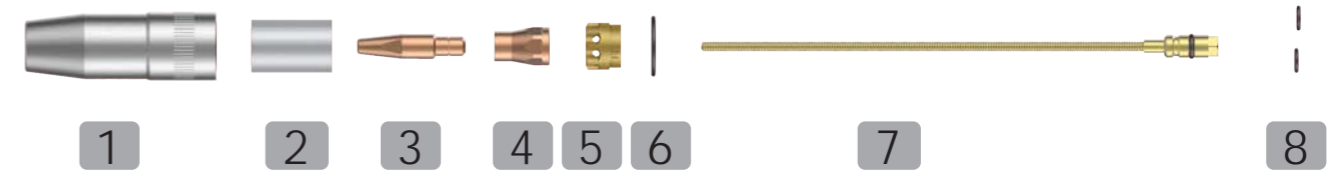

Pos.	TYPE	CODE	Min. Q.
1	Nozzle L76xØ15.5 mm	R10 0011	2
	Nozzle L76xØ13 mm	R10 0012	2
	Nozzle L79xØ15.5 mm	R10 0211	2
2	Insulator nozzle L35xØ19.5 mm	R10 0002	2
3	Contact tip M10 1.0 mm Cu-BICOMP	R10 0400 10	5
	Contact tip M10 1.2 mm Cu-BICOMP	R10 0400 12	5
	Contact tip M10 1.6 mm Cu-BICOMP	R10 0400 16	5
	Contact tip M10 1.2 mm Cu-BICOMP Alum	R10 0400 12A	5
	Contact tip M10 1.6 mm Cu-BICOMP Alum	R10 0400 16A	5
	Contact tip M10 0.8 mm CuCrZr	R10 0401 08	10
	Contact tip M10 1.0 mm CuCrZr	R10 0401 10	10
	Contact tip M10 1.2 mm CuCrZr	R10 0401 12	10
	Contact tip M10 1.6 mm CuCrZr	R10 0401 16	10
	4	Tip holder L22xØ15 mm M10	R10 0013
5	Diffuser Insulator neck L14xØ18.5 mm	R12 0404	2
6	Oring neck Ø23 mm	R10 0401	10
	Liner for neck type N 217mm	R10 1112	1
7	Liner for neck type L 267mm	R10 1113	1
	Oring neck water Ø9 mm	R12 0008	10



Pos.	TYPE	CODE	Min. Q.
9	Tip TCP M10-15mm programming	R10 0115	1
10	Neck tool BOT	R04 0000	1
11	Clining reamer TH L26xØ15x10.5mm	R03 2040	1

STANDARD MEASURES

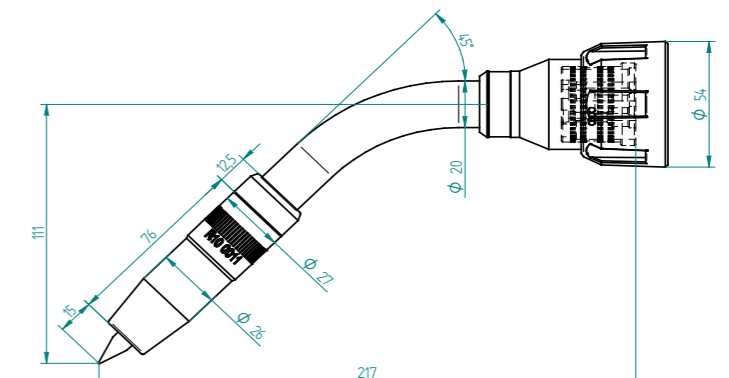



Welding process:
MIG/MAG, GMAW, 131,135
Technical data according to IEC60974-7



Liquid



550 A - CO2 100%



450 A - Mix M21 (ISO 14175) 100%



Ø 1.0-1.6 mm



10-18 l/min

The capacity will be reduced by 35% when pulsed arc.

Versatile MIG / MAG neck model as its lower power 40W model, but with an additional cooling in its open circuit nozzle to withstand more extreme conditions, high work capacity and adaptable to a multitude of robotic and automatic applications, versatile model and powerful.

The welding systems for industrial robots BOTseries are designed for work cycles of 24 hours, developed for an intensive use, precise and specifically adapted to long work cycles.

STANDARD CONFIGURATION

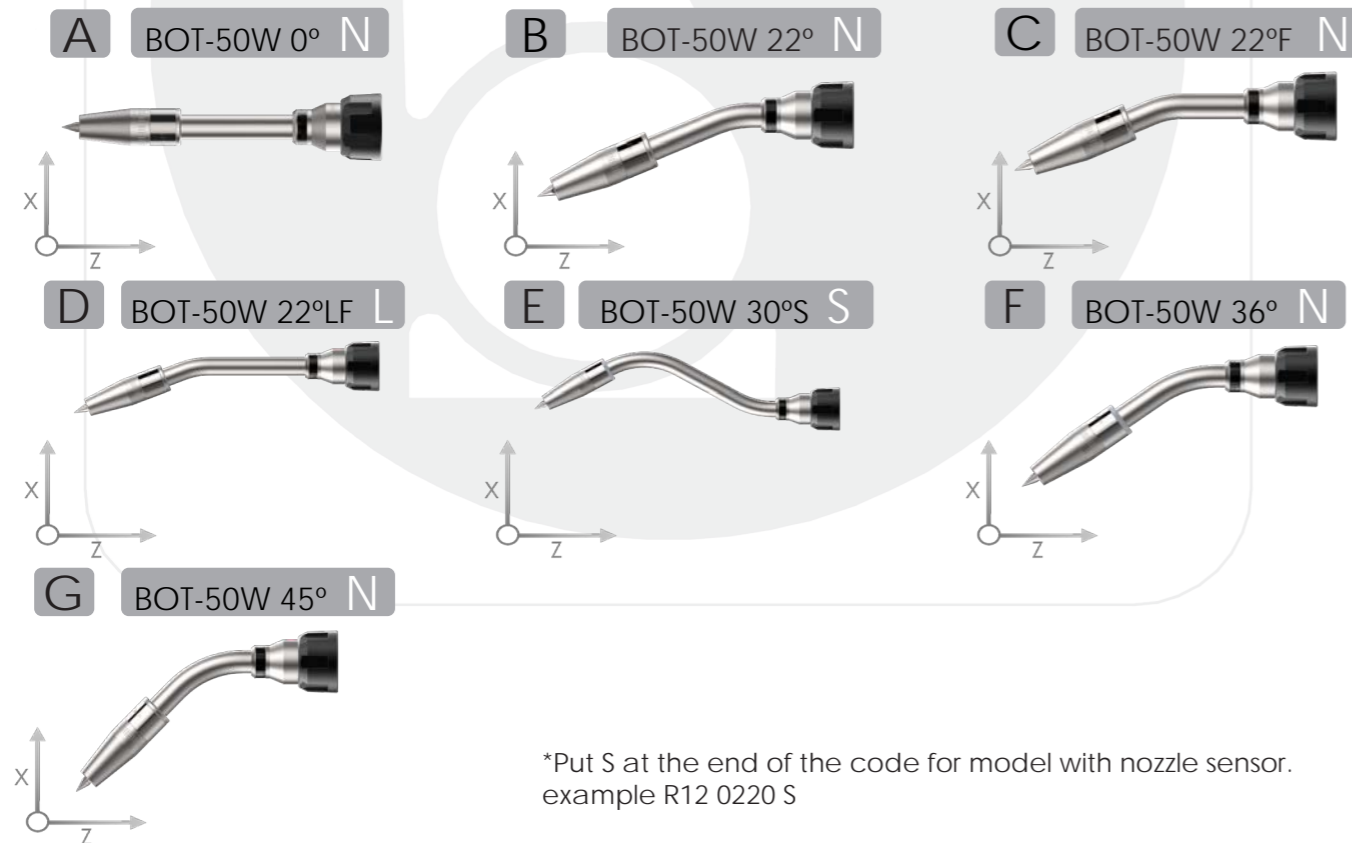

*Put S at the end of the code for model with nozzle sensor.
example R12 0220 S

Pos.	TYPE	CODE	Min. Q.
A	Torch neck BOT-50W 0° (X=0 mm, Z=259 mm)-long type N	R15 0000	1
B	Torch neck BOT-50W 22° (X=64 mm, Z=247 mm)-long type N	R15 0220	1
C	Torch neck BOT-50W 22°F (X=50 mm, Z=250 mm)-long type N	R15 0221	1
D	Torch neck BOT-50W 22°LF (X=50 mm, Z=300 mm)-long type L	R15 0222	1
E	Torch neck BOT-50W 30°S (X=0 mm, Z=347 mm)-long type S	R15 0303	1
F	Torch neck BOT-50W 36° (X=96 mm, Z=230 mm)-long type N	R15 0360	1
G	Torch neck BOT-50W 45° (X=111 mm, Z=217 mm)-long type N	R15 0450	1

enDS-BOT50W-02

SPARE PARTS

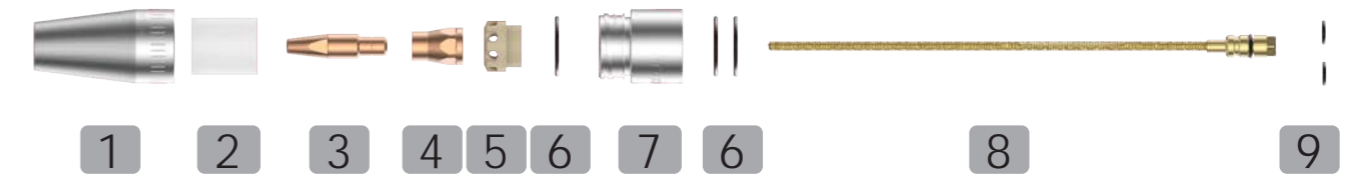

Pos.	TYPE	CODE	Min. Q.
1	Nozzle L60xØ15.5 mm	R12 0551	2
	Nozzle L60xØ18 mm	R12 0552	2
2	Insulator nozzle L28XØ23 mm	R10 0602	2
	Contact tip M10 1.0 mm Cu-BICOMP	R10 0400 10	5
	Contact tip M10 1.2 mm Cu-BICOMP	R10 0400 12	5
	Contact tip M10 1.6 mm Cu-BICOMP	R10 0400 16	5
	Contact tip M10 1.2 mm Cu-BICOMP Alum	R10 0400 12A	5
	Contact tip M10 1.6 mm Cu-BICOMP Alum	R10 0400 16A	5
	Contact tip M10 0.8 mm CuCrZr	R10 0401 08	10
	Contact tip M10 1.0 mm CuCrZr	R10 0401 10	10
	Contact tip M10 1.2 mm CuCrZr	R10 0401 12	10
	Contact tip M10 1.6 mm CuCrZr	R10 0401 16	10
4	Tip holder L22xØ15 mm M10	R10 0013	2
5	Diffuser Insulator neck L16XØ20.5 mm	R12 0604	2
6	Oring neck Ø24 mm	R12 0607	10
	Nozzle support L36XØ30 mm	R12 0550	1
	Liner for neck type N 217mm	R10 1112	1
7	Liner for neck type L 267mm	R10 1113	1
	Liner for neck type S 330mm	R10 1115	1
9	Oring neck water Ø9	R12 0008	10



Pos.	TYPE	CODE	Min. Q.
10	Tip TCP M10-15mm programming	R10 0115	1
11	Neck tool BOT	R04 0000	1
12	Clining reamer TH L26xØ17.5x10.5mm	R03 2050	1

STANDARD MEASURES

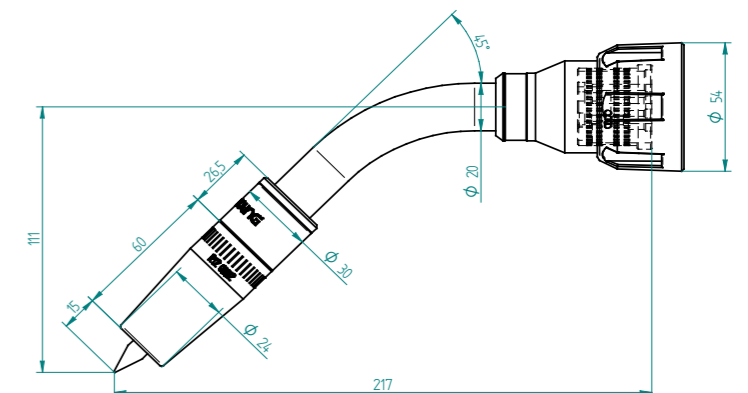



Welding process:
MIG/MAG, GMAW, 131,135
Technical data according to IEC60974-7

CE

- Liquid
- 600 A - CO2 100%
- 500 A - Mix M21 (ISO 14175) 100%
- Ø 1.0-2.4 mm
- 10-20 l/min

The capacity will be reduced by 35% whit pulsed arc.

High power MIG / MAG neck model, for applications where the work cycles are long and high power, recharge, beams, very high work intensity and adaptable to a multitude of robotic and automatic applications, the most powerful model with contribution of a single thread.

The welding systems for industrial robots BOTseries are designed for work cycles of 24 hours, developed for an intensive use, precise and specifically adapted to long work cycles.

STANDARD CONFIGURATION

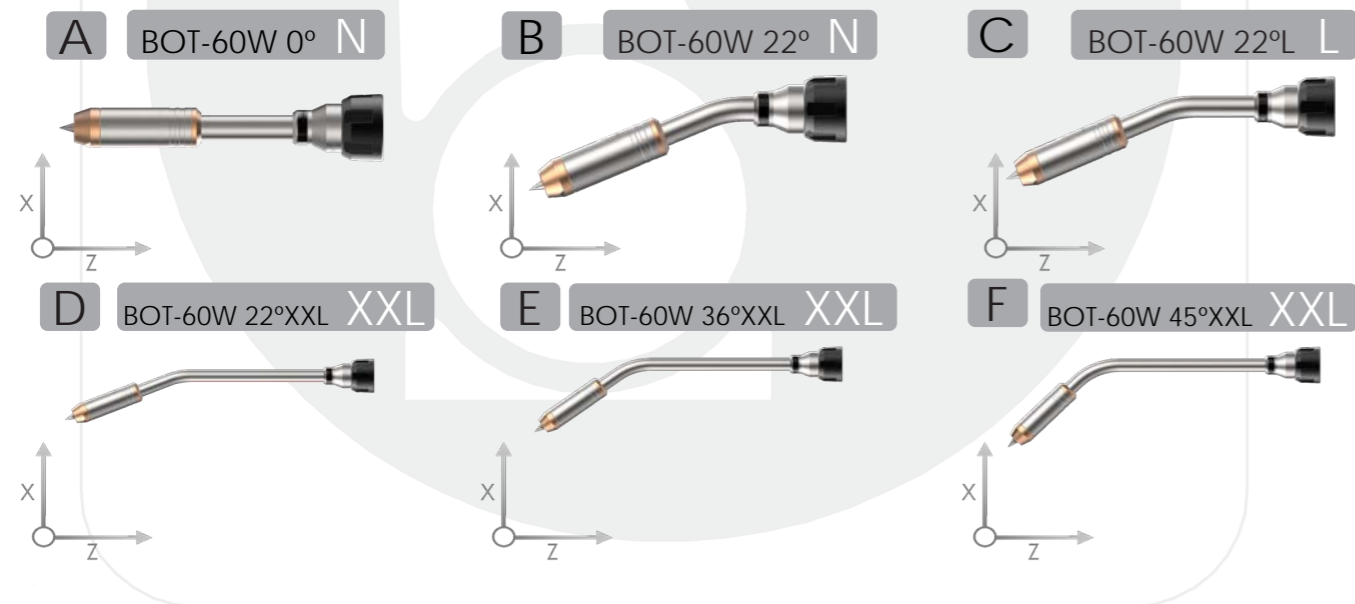

*Put S at the end of the code for model with nozzle sensor.
example R12 0220 S

Pos.	TYPE	CODE	Min. Q.
A	Torch neck BOT-60W 0° (X=0 mm, Z=259 mm)-long type N	R16 0000	1
B	Torch neck BOT-60W 22° (X=64 mm, Z=247 mm)-long type N	R16 0220	1
C	Torch neck BOT-60W 22°L (X=64 mm, Z=297 mm)-long type L	R16 0221	1
D	Torch neck BOT-60W 22°XXL (X=69 mm, Z=453 mm)-long type XXL	R16 0224	1
E	Torch neck BOT-60W 36°XXL (X=103 mm, Z=435 mm)-long type XXL	R16 0364	1
F	Torch neck BOT-60W 45°XXL (X=121 mm, Z=419 mm)-long type XXL	R16 0454	1

enDS-BOT50W-02

SPARE PARTS

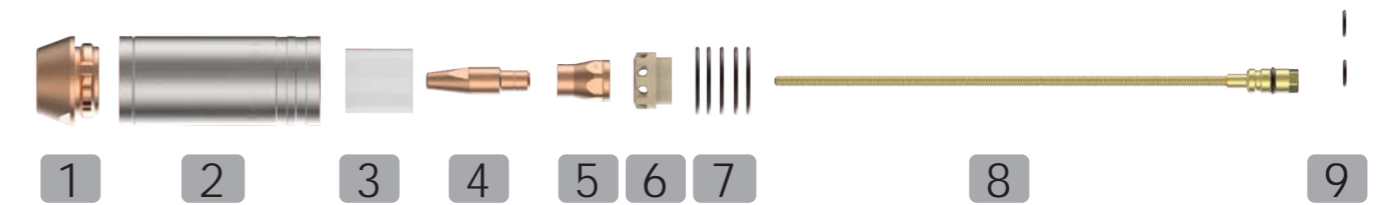

Pos.	TYPE	CODE	Min. Q.	
1	Nozzle L16xØ15.5 mm	R12 0611	2	
	Nozzle L16xØ18 mm	R12 0612	2	
	Nozzle L16xØ21 mm	R12 0613	2	
2	Nozzle support L83XØ32 mm	R12 0609	1	
3	Insulator nozzle L28XØ23 mm	R10 0602	2	
	Contact tip M10 1.0 mm Cu-BICOMP	R10 0400 10	5	
	Contact tip M10 1.2 mm Cu-BICOMP	R10 0400 12	5	
	Contact tip M10 1.6 mm Cu-BICOMP	R10 0400 16	5	
	Contact tip M10 1.2 mm Cu-BICOMP Alum	R10 0400 12A	5	
	Contact tip M10 1.6 mm Cu-BICOMP Alum	R10 0400 16A	5	
	Contact tip M10 0.8 mm CuCrZr	R10 0401 08	10	
	Contact tip M10 1.0 mm CuCrZr	R10 0401 10	10	
	Contact tip M10 1.2 mm CuCrZr	R10 0401 12	10	
	Contact tip M10 1.6 mm CuCrZr	R10 0401 16	10	
	Contact tip M10 2.4 mm CuCrZr	R10 0401 24	bp	
	5	Tip holder L22xØ15 mm M10	R10 0013	2
	6	Diffuser insulator neck L16XØ20.5 mm	R12 0604	2
7	Oring neck Ø24 mm	R12 0607	10	
	Liner for neck type N 217mm	R10 1112	1	
	Liner for neck type L 267mm	R10 1113	1	
	Liner for neck type XXL 421mm	R10 1116	1	



Pos.	TYPE	CODE	Min. Q.
10	Tip TCP M10-18mm programming	R10 0118	1
11	Neck tool BOT	R04 0000	1
12	Clining reamer TH L29xØ17.5x10.5mm	R03 2060	1

STANDARD MEASURES

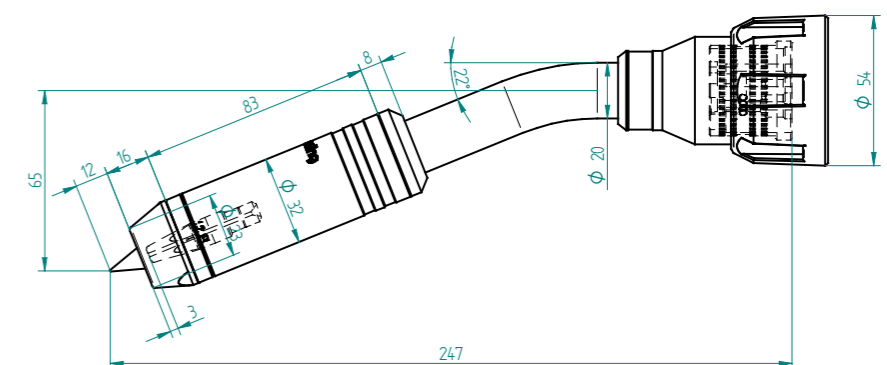



Welding process:
TIG, GTAW, 141
Technical data according to IEC60974-7

CE

- Liquid
- 400 A - CD 100%
- 300 A - AC 100%
- Ø 1.6-4.0 mm
- 4-12 l/min

The capacity will be reduced by 35% with pulsed arc.

Line of COBOT torches adapts perfectly to all the requirements of collaborative robots due to its low weight and functionality. This model has the capacity to connect an anti-collision system and adjustment of the position angle of the wire

STANDARD CONFIGURATION

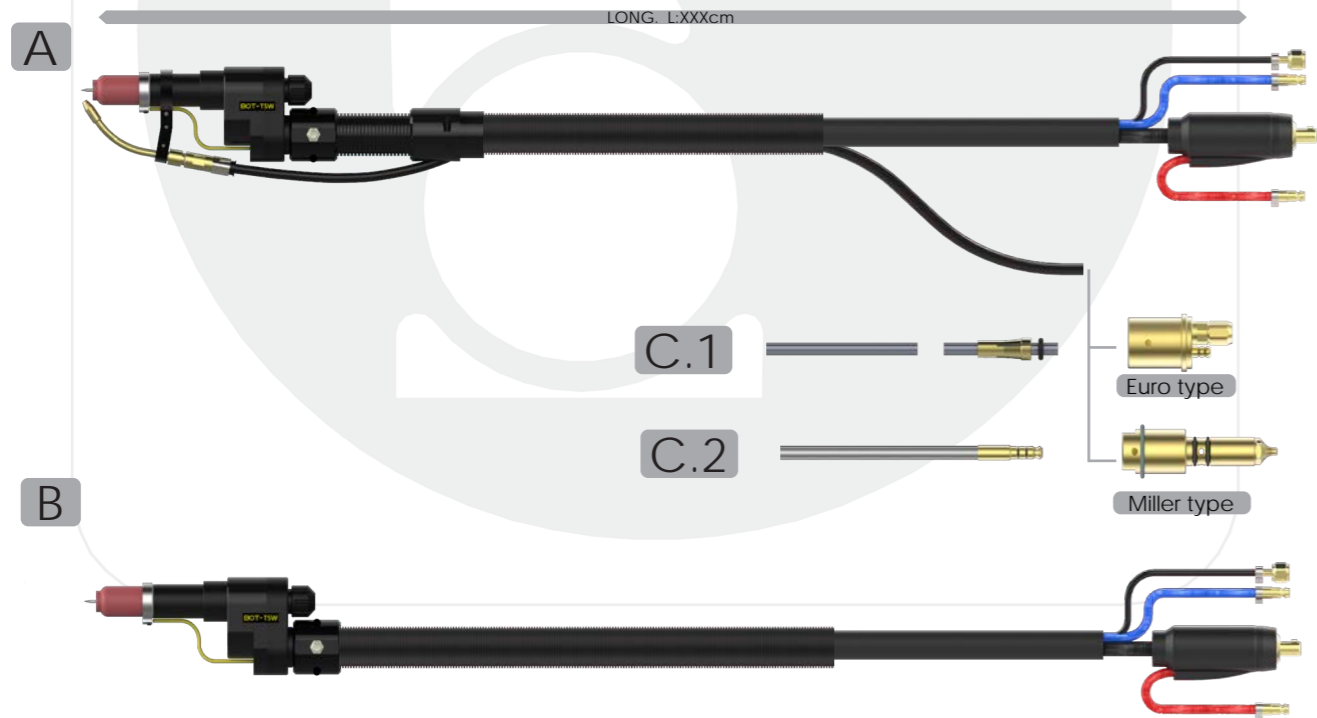

Pos.	TYPE	CODE	Min. Q.
A	Welding torch TIG T5W - COLD WIRE Euro type	R97 8xxx E	1
	Welding torch TIG T5W - COLD WIRE Miller type	R97 8xxx M	
B	Welding torch TIG T5W	R97 8xxx	1
C.1	Guide TEFLON itBOT L2700xD4xD2mm(1.0-1.2)-Euro	M99 8002	1
	Guide TEFLON itBOT L3700xD4xD2mm(1.0-1.2)-Euro	M99 8003	1
C.2	Guide TEFLON itBOT L2700xD4xD2mm(1.0-1.2)-Miller	M99 1502	1
	Guide TEFLON itBOT L3700xD4xD2mm(1.0-1.2)-Miller	M99 1503	1

enDS-T5W-00

SPARE PARTS

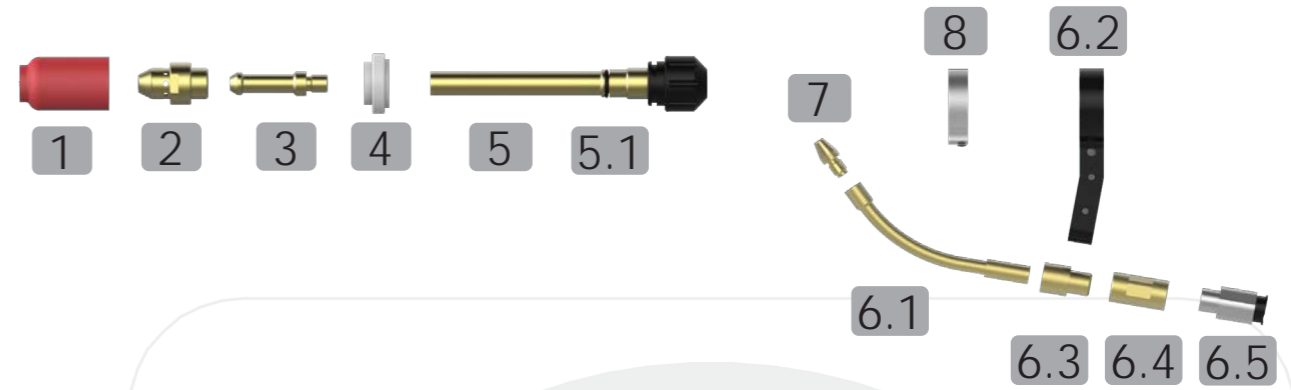

Pos.	TYPE	CODE	Min. Q.
1	Nozzle G6	T54N16	10
	Nozzle G7	T54N15	10
	Nozzle G8	T54N14	10
2	Diffuser M14 2.4mm	R15 5304	2
	Diffuser M14 3.2mm	R15 5305	2
3	Electrode holder 2.4 mm	R15 5524	2
	Electrode holder 3.2 mm	R15 5532	2
4	Insulator Nozzle	R15 5303	2
5	Clamping element	R15 5502	1
5.1	Oring clamping element	R15 0502	5
6.1	Wire guide	R15 0021	1
6.2	Support wire guide	R15 0301	1
6.3	Support liner	R15 0024	1
6.4	Liner Fixing nut support	R15 0026	1
6.5	Tube fitting D8	R15 0027	1
7	Tip Dia. 1.0 mm	R15 0110	5
	Tip Dia. 1.2 mm	R15 0112	5
8	HF protective ring	R15 0603	1

Pos.	TYPE	CODE	Min. Q.
8	Bracket TIG T5W 30°	R41 5001	1

MEASURES

WEIGHT
1.320kg

CG CENTER OF GRAVITY
X=0 mm
Y=61.2mm
Z=72.9 mm

TCP TOOL CENTER POINT
X=0 mm
Y=50 mm
Z=246 mm

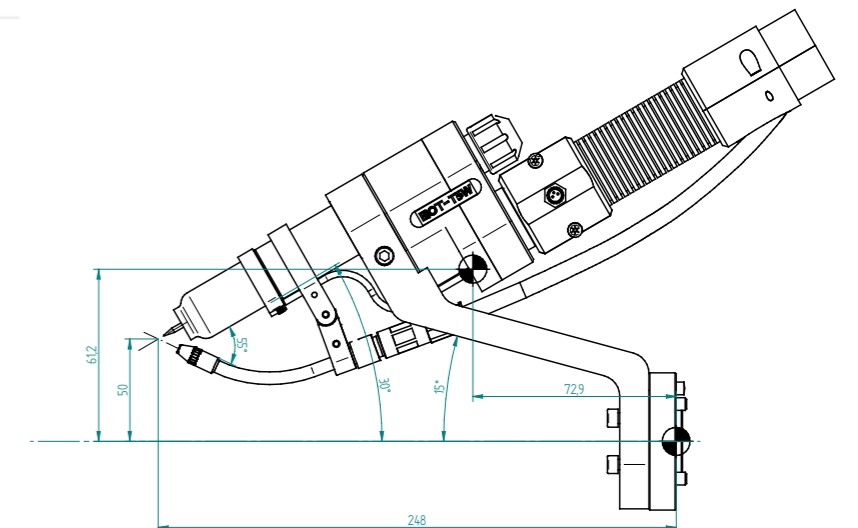

MIG / MAG Power cable system

2

Robotic power cables MIG / MAG liquid / gas cooling.

- iBOT power cable 34 Pag.
- eBOT power cable 36 Pag.





Welding process:
MIG/MAG, GMAW, 131,135
Technical data according to IEC60974-7



- Liquid / Gas
- 600 A - 100% / 500 A - 100%
- Turn +-360° / Turn +-240°

WIRE BRAKE MODULE

Air pressure Wire Brake piston 6-8 bars
Compatible welding wire 1.0 1.2 mm
Compressed air tube, diameter 4 mm

All the packages of power of the BOT oversized for cycles of work of 24 hours, and with materials highly resistant to the mechanical fatigue like the PU, PA12, his system of 4 conduits of power for refrigeration by liquid is extremely flexible with capacities of turn above our competitors up to 720°.

The welding systems for industrial robots BOTseries developed for an intensive use, precise and specifically adapted to long work cycles.

STANDARD CONFIGURATION-POWER CABLE

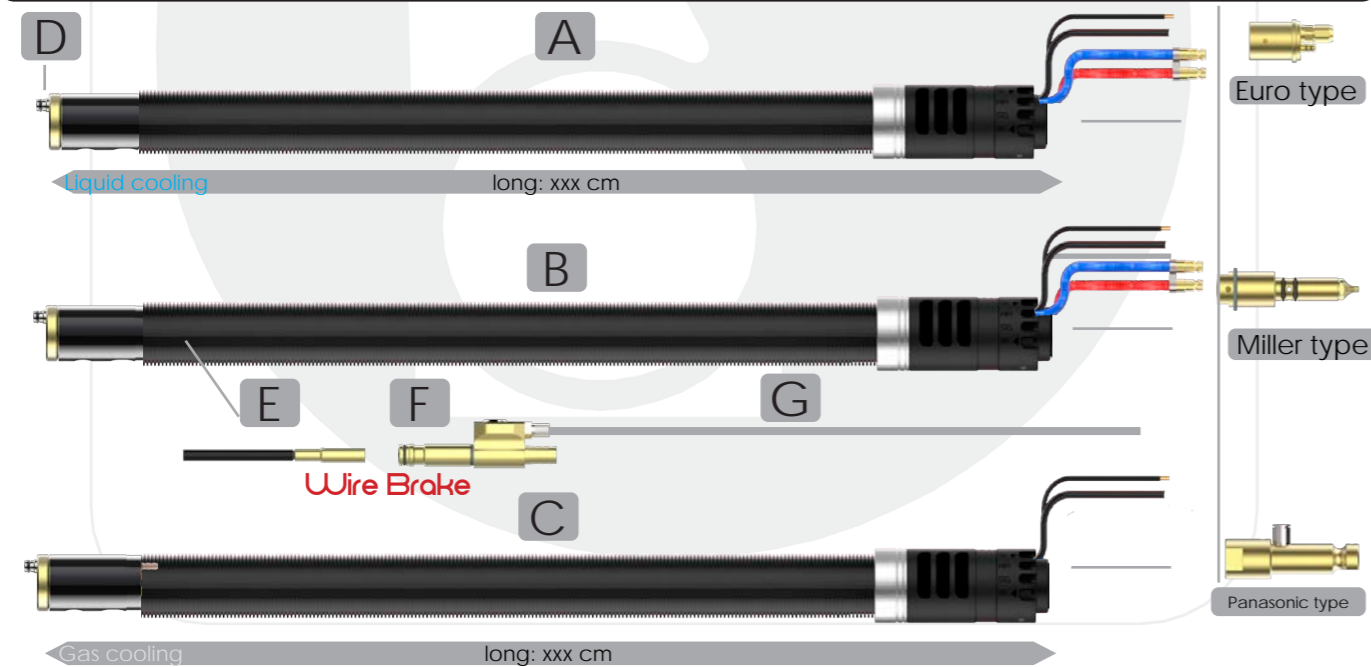

Pos.	TYPE	CODE	Min. Q.
A.1	Power cable liquid iBOT-Euro type	R95 1xxx	1
A.2	Power cable liquid iBOT-Miller type	R95 2xxx	1
A.3	Power cable liquid iBOT-Panasonic type	R95 3xxx	1
B.1	Power cable liquid iBOT-Euro type - WIRE BRAKE	R95 1xxxWB	1
B.2	Power cable liquid iBOT-Miller type - WIRE BRAKE	R95 2xxxWB	1
B.3	Power cable liquid iBOT-Panasonic type - WIRE BRAKE	R95 3xxxWB	1
C.1	Power cable gas iBOT-Euro type	R94 1xxx	1
C.2	Power cable gas iBOT-Miller type	R94 2xxx	1
C.3	Power cable gas iBOT-Panasonic type	R94 3xxx	1
D	Oring power cable gas Ø9	R20 0603	10
E	Liner for wire brake wire 1.0 - 1.2 mm	R90 4004WB	1
F	Pneumatic tube D4mm (mts)	R9 0400 05	1
G	Set of wire brake locking system	R9 0400	1

enDS-iBOT PC-02

SPARE PARTS-GUIDES

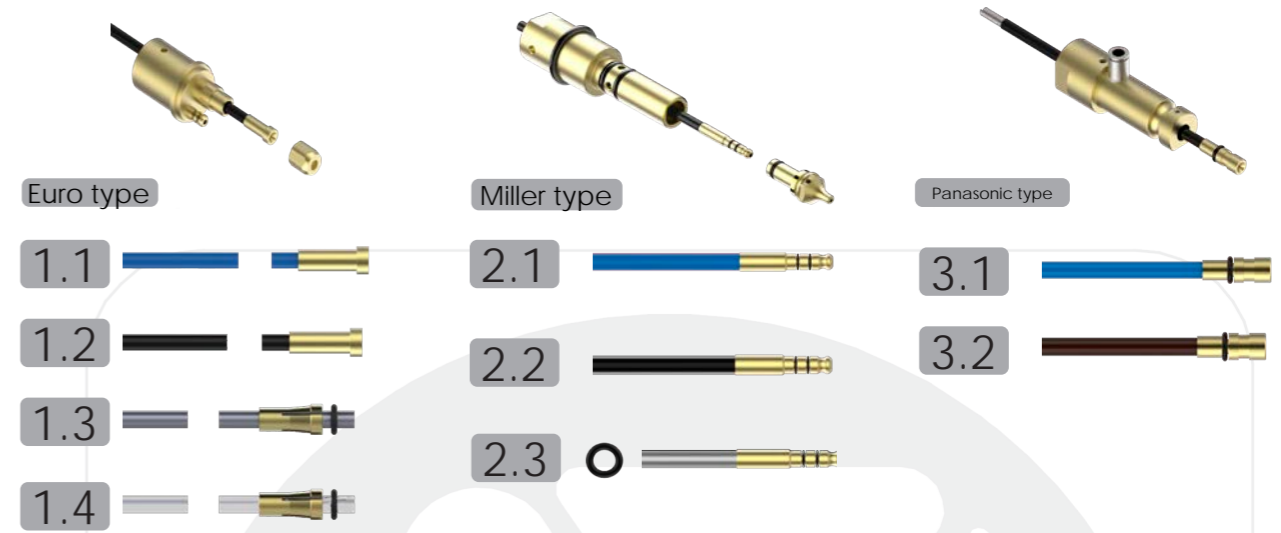

Pos.	TYPE	CODE	Min. Q.
1.1	Guide blue L1600xD4.6xD1.5mm(0.8-1.0)-Euro	M99SR01B	1
	Guide blue L2600xD4.6xD1.5mm(0.8-1.0)-Euro	M99SR02B	1
1.2	Guide black L1600xD5.3xD2.2mm(1.2-1.6)-Euro	M99 4001	1
	Guide black L2600xD5.3xD2.2mm(1.2-1.6)-Euro	M99 4002	1
1.3	Guide for Alum BOT L1700xD4.5xD2.5mm(1.2-1.6)-Euro	M99 7001	1
	Guide for Alum BOT L2700xD4.5xD2.5mm(1.2-1.6)-Euro	M99 7002	1
1.4	Guide TEFLON itBOT L1700xD4xD2mm(1.0-1.2)-Euro	M99 8001	1
	Guide TEFLON itBOT L2700xD4xD2mm(1.0-1.2)-Euro	M99 8002	1
2.1	Guide blue L1600xD4.6xD1.5mm(0.8-1.0)-Miller	M99 1001	1
	Guide blue L2600xD4.6xD1.5mm(0.8-1.0)-Miller	M99 1002	1
2.2	Guide black L1600xD5.3xD2.2mm(1.2-1.6)-Miller	M99 1101	1
	Guide black L2600xD5.3xD2.2mm(1.2-1.6)-Miller	M99 1102	1
2.3	Guide for Alum BOT L1700xD4.5xD2.5mm(1.2-1.6)-Miller	M99 1401	1
	Guide for Alum BOT L2700xD4.5xD2.5mm(1.2-1.6)-Miller	M99 1402	1
3.1	Guide blue L1600xD4.6xD1.5mm(0.8-1.0)-Panasonic	M99 1301	1
	Guide blue L2600xD4.6xD1.5mm(0.8-1.0)-Panasonic	M99 1302	1
3.2	Guide black L1600xD5.3xD2.2mm(1.2-1.6)-Panasonic	M99 1201	1
	Guide black L2600xD5.3xD2.2mm(1.2-1.6)-Panasonic	M99 1202	1

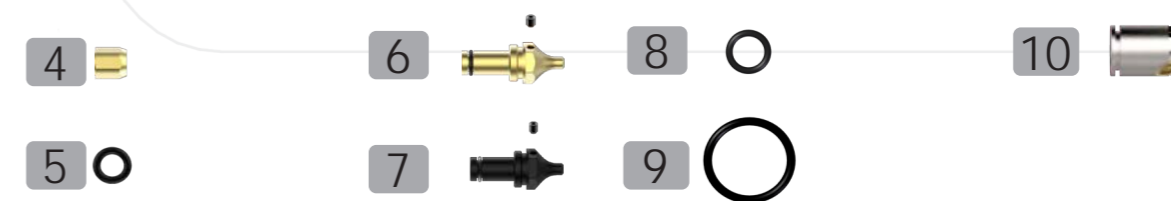

Pos.	TYPE	CODE	Min. Q.
4	Guide cap Euro-BOT	R6 0000 04	1
5	O-ring gas connection Euro	R2 2000 0206	10
6	Guide cap Miller-BOT	R60 0014	1
7	Guide cap Alum. Miller-BOT	R60 0114	1
8	O-ring gas connection Miller	R6 0001 02	4
9	O-ring protection Miller-BOT	R6 0203 02	2
10	Tube gas connector D6	R6 0202 03	1

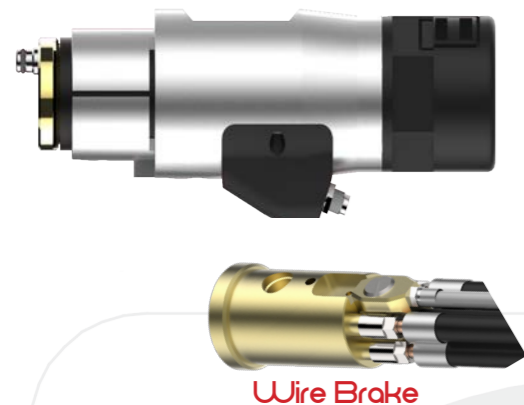

Wire Brake

Welding process:
MIG/MAG, GMAW, 131,135
Technical data according to IEC60974-7

- Liquid / Gas
- 600 A - 100% / 500 A - 100%

WIRE BRAKE MODULE

Air pressure Wire Brake piston 6-8 bars
Compatible welding wire 1.0 1.2 mm
Compressed air tube, diameter 4 mm

All the packages of power of the BOT oversized for cycles of work of 24 hours, and with materials highly resistant to the mechanical fatigue like the PU, PA12.

The welding systems for industrial robots BOTseries are designed for work cycles of 24 hours, developed for an intensive use, precise and specifically adapted to long work cycles.

STANDARD CONFIGURATION-POWER CABLE

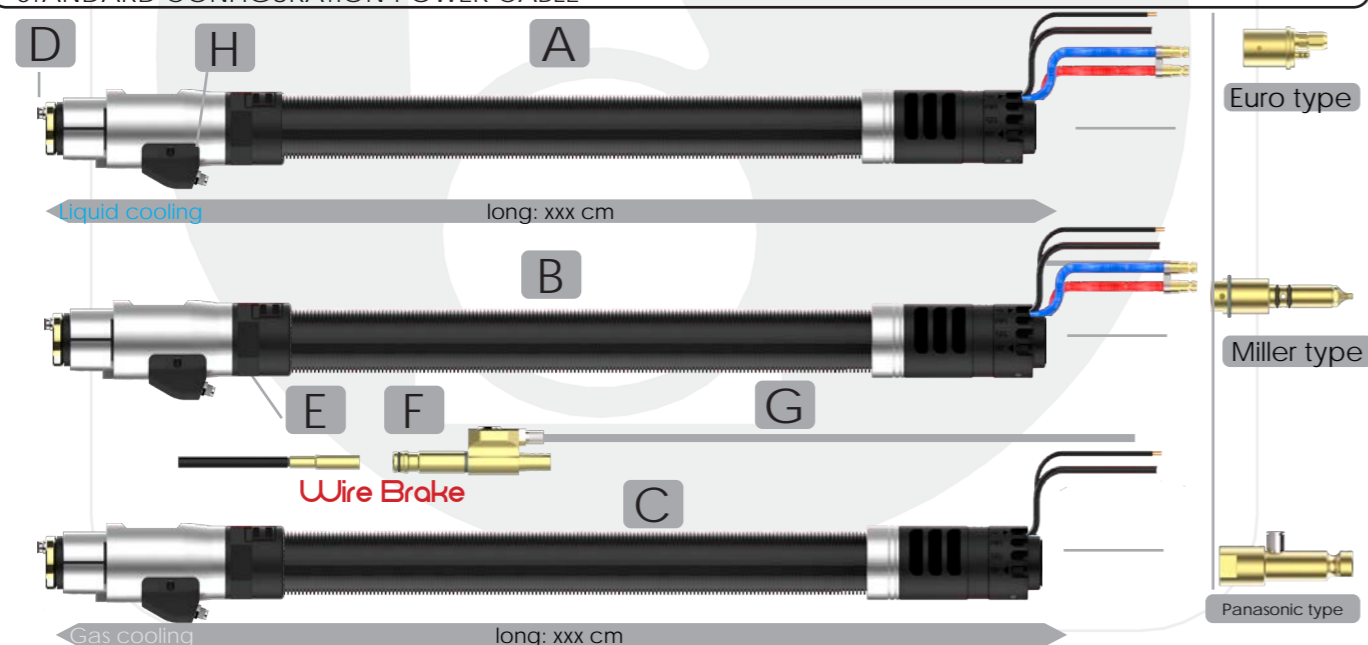

Pos.	TYPE	CODE	Min. Q.
A.1	Power cable liquid eBOT-Euro type	R92 1xxx	1
A.2	Power cable liquid eBOT-Miller type	R92 2xxx	1
A.3	Power cable liquid eBOT-Panasonic type	R92 3xxx	1
B.1	Power cable liquid eBOT-Euro type -WIRE BRAKE	R92 1xxxWB	1
B.2	Power cable liquid eBOT-Miller type - WIRE BRAKE	R92 2xxxWB	1
B.3	Power cable liquid eBOT-Panasonic type - WIRE BRAKE	R92 3xxxWB	1
C.1	Power cable gas eBOT-Euro type	R91 1xxx	1
C.2	Power cable gas eBOT-Miller type	R91 2xxx	1
C.3	Power cable gas eBOT-Panasonic type	R91 3xxx	1
D	Oring power cable gas Ø9	R20 0603	10
E	Liner for wire brake wire 1.0 - 1.2 mm	R90 4004WB	1
F	Pneumatic tube D4mm (mts)	R9 0400 05	1
G	Set of wire brake locking system	R9 0400	1
H	Connections Box	R30 0003	1

enDS-eBOT PC-02

GUIDES-SPARE PARTS

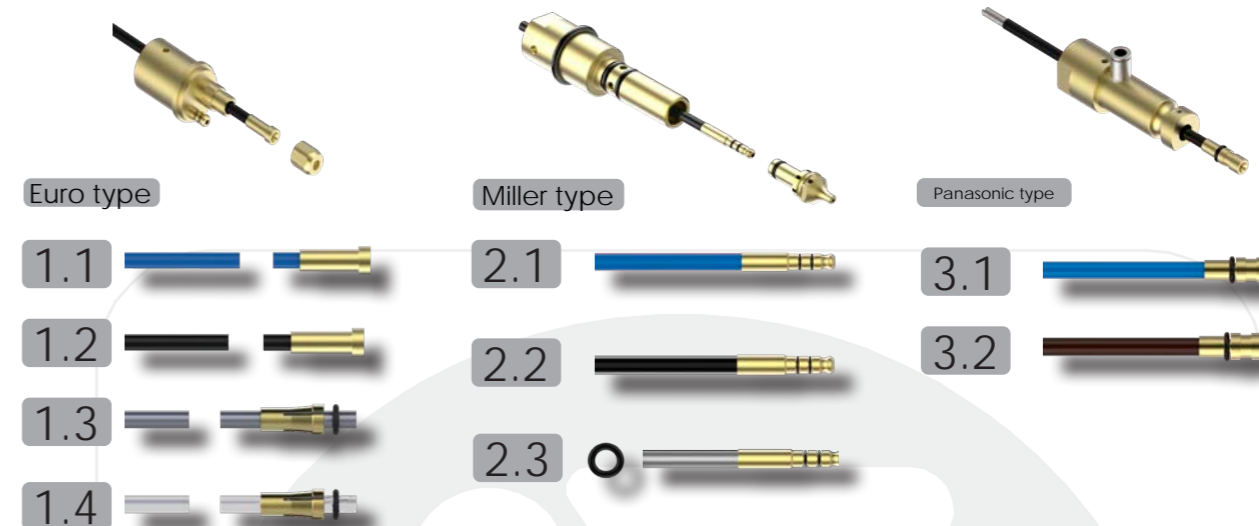

Pos.	TYPE	CODE	Min. Q.
1.1	Guide blue L1600xD4.6xD1.5mm(0.8-1.0)-Euro	M99SR01B	1
	Guide blue L2600xD4.6xD1.5mm(0.8-1.0)-Euro	M99SR02B	1
1.2	Guide black L1600xD5.3xD2.2mm(1.2-1.6)-Euro	M99 4001	1
	Guide black L2600xD5.3xD2.2mm(1.2-1.6)-Euro	M99 4002	1
1.3	Guide for Alum BOT L1700xD4.5xD2.5mm(1.2-1.6)-Euro	M99 7001	1
	Guide for Alum BOT L2700xD4.5xD2.5mm(1.2-1.6)-Euro	M99 7002	1
1.4	Guide TEFLON itBOT L1700xD4xD2mm(1.0-1.2)-Euro	M99 8001	1
	Guide TEFLON itBOT L2700xD4xD2mm(1.0-1.2)-Euro	M99 8002	1
2.1	Guide blue L1600xD4.6xD1.5mm(0.8-1.0)-Miller	M99 1001	1
	Guide blue L2600xD4.6xD1.5mm(0.8-1.0)-Miller	M99 1002	1
2.2	Guide black L1600xD5.3xD2.2mm(1.2-1.6)-Miller	M99 1101	1
	Guide black L2600xD5.3xD2.2mm(1.2-1.6)-Miller	M99 1102	1
2.3	Guide for Alum BOT L1700xD4.5xD2.5mm(1.2-1.6)-Miller	M99 1401	1
	Guide for Alum BOT L2700xD4.5xD2.5mm(1.2-1.6)-Miller	M99 1402	1
3.1	Guide blue L1600xD4.6xD1.5mm(0.8-1.0)-Panasonic	M99 1301	1
	Guide blue L2600xD4.6xD1.5mm(0.8-1.0)-Panasonic	M99 1302	1
3.2	Guide black L1600xD5.3xD2.2mm(1.2-1.6)-Panasonic	M99 1201	1
	Guide black L2600xD5.3xD2.2mm(1.2-1.6)-Panasonic	M99 1202	1

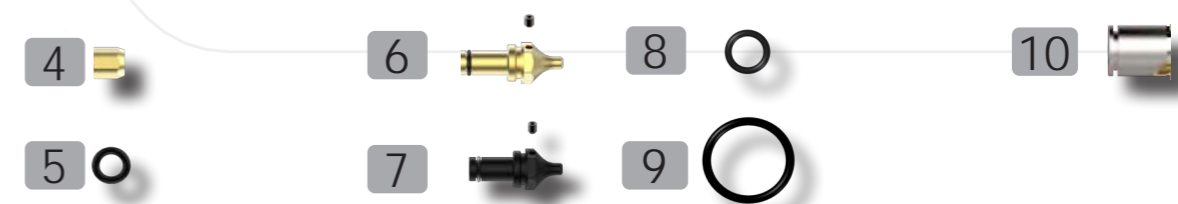

Pos.	TYPE	CODE	Min. Q.
4	Guide cap Euro-BOT	R6 0000 04	1
5	O-ring gas connection Euro	R2 2000 0206	10
6	Guide cap Miller-BOT	R60 0014	1
7	Guide cap Alum. Miller-BOT	R60 0114	1
8	O-ring gas connection Miller	R6 0001 02	4
9	O-ring protection Miller-BOT	R6 0203 02	2
10	Tube gas connector D6	R6 0202 03	1



FOURpower
720°

Welding process: MIG/MAG, GMAW, 131,135
Technical data according to IEC60974-7

CE

- Liquid: 600 A - 100%
- Gas: 500 A - 100%

STANDARD CONFIGURATION-POWER CABLE

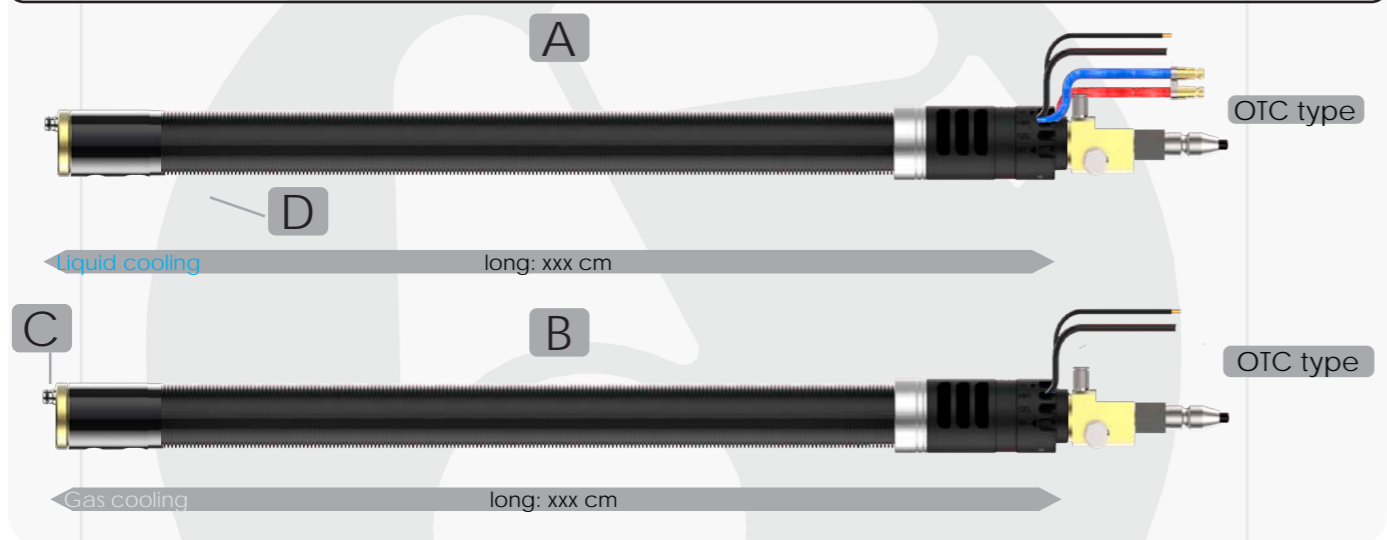

Pos.	TYPE	CODE	Min. Q.
A.1	Power cable liquid iBOT-OTC type	R95 4xxx	1
B.1	Power cable gas iBOT-OTC type	R94 4xxx	1
C	Oring power cable gas Ø9	R20 0603	10

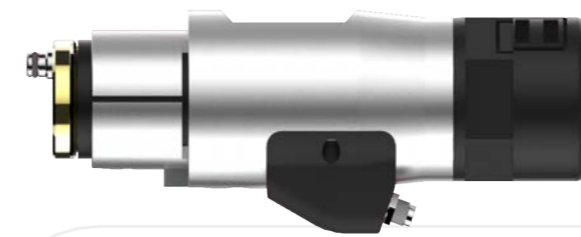

Welding process: MIG/MAG, GMAW, 131,135
Technical data according to IEC60974-7

CE

- Liquid: 600 A - 100%
- Gas: 500 A - 100%

STANDARD CONFIGURATION-POWER CABLE

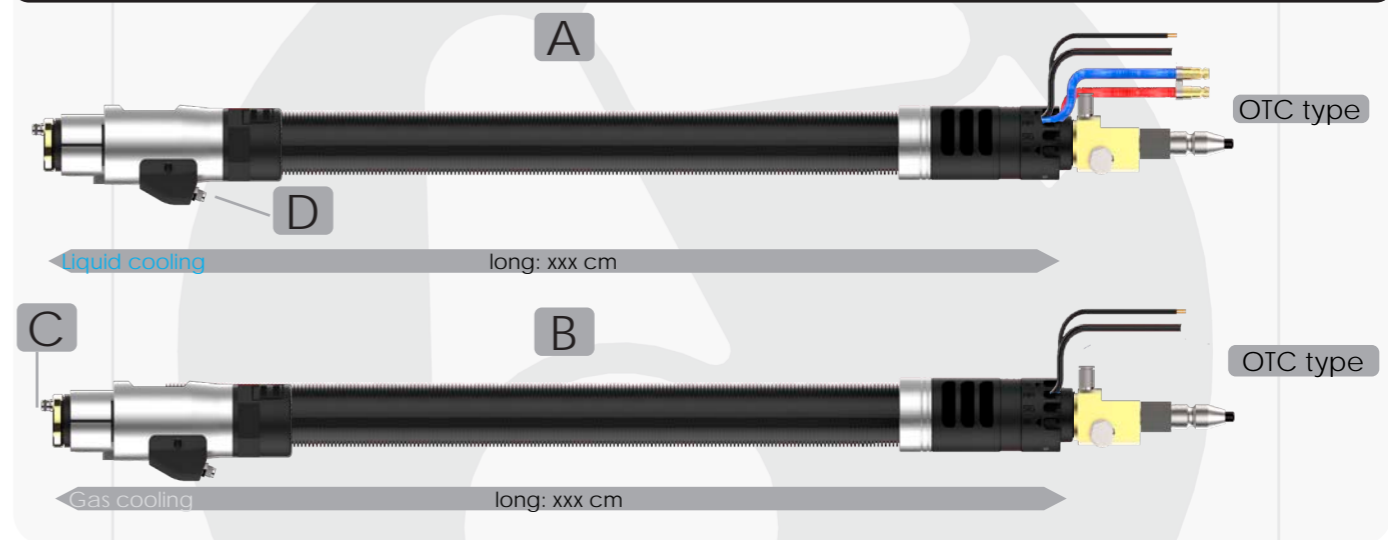

Pos.	TYPE	CODE	Min. Q.
A.1	Power cable liquid eBOT-OTC type	R92 4xxx	1
B.1	Power cable gas eBOT-OTC type	R91 4xxx	1
C	Oring power cable gas Ø9	R20 0603	10
D	Connections Box	R30 0003	1

SPARE PARTS-GUIDES

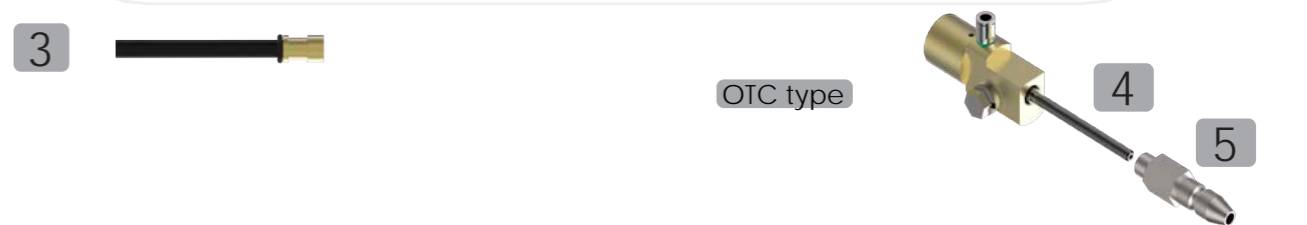

Pos.	TYPE	CODE	Min. Q.
3	Guide black for steel L1600xD5.3xD2.2mm(1.0-1.2)-OTC	M99 OTN1	1
	Guide black for steel L2600xD5.3xD2.2mm(1.0-1.2)-OTC	M99 OTN2	1
	Guide for alum L1600xD4.5xD2.5mm(1.0-1.2)-OTC	M99 OTAL1	1
	Guide for steel L2600xD4.3xD2.5mm(1.0-1.2)-OTC	M99 OTAL2	1
4	Guide wire steel 2.5 OTC	R6 OTC1	1
	Guide wire PA (for Alum) 2.5 OTC	R6 OTC1*	1
5	Guide support wire OTC	R6 OTC2	1

Anti-collision system



Anti-collision systems BOT MIG / MAG

iBOT	42 Pag.
eBOT	44 Pag.





Welding process:
MIG/MAG, GMAW, 131,135



930 gr



L100 x Ø96 mm



Max. X,Y:10° / Z:7mm



Sensor X,Y:1° / Z:0.7mm



Sensor 250V DC-100mA-NC



Max. 2.5 kg



0.1 to 300 mm

iBOT system for robots with hollow wrist shaft and internal wiring to axis 6.

Anti-collision system for hollow shaft welding robots eBOT developed with the latest machining technology, the system gives maximum precision for the protection of your welding devices and can be adapted to any robot.

Advantages of the iBOT anti-collision.

- They are compatible with all industrial hollow wrist robots.
- Total protection of internal screws and sensors with IP64, prevents the accumulation of projections.
- 6 internal support points avoids zones of lower flexural strength improving the failure alarms due to inertias, this allows to increase the speed of movement of the robot.
- Independent of the power cable system, facilitating the repair and replacement of the power cables.
- Manufactured in tempered steel and aeronautical aluminum 7075.
- Maintains its accuracy for different loads, thanks to its patented springs system.

SPARE PARTS

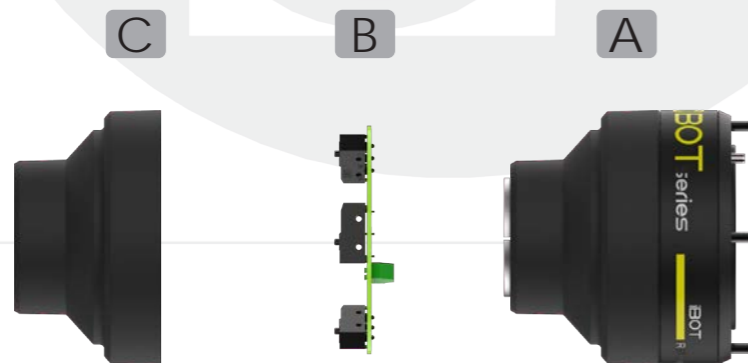

Pos.	TYPE	CODE	Min. Q.
1	Anti-collision iBOT	R51 0001	1
1.1	Anti-collisión sensor BOT	R50 0014	1
1.2	Protection cover iBOT/itBOT	R51 0011	1

STANDARD MEASURES

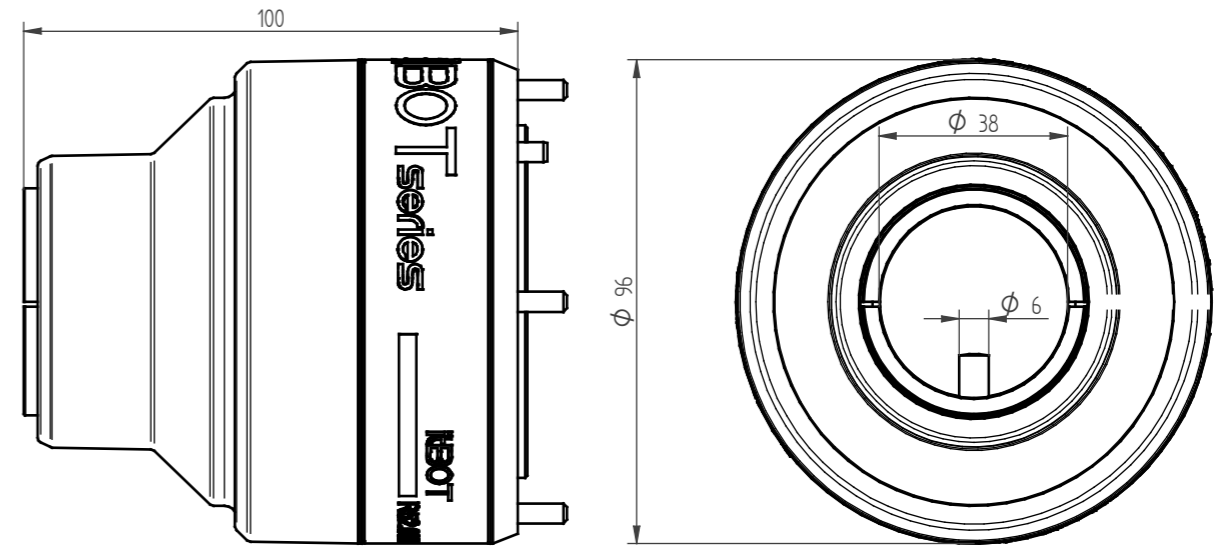



Welding process:
MIG/MAG, GMAW, 131,135



910 gr



L62 x Ø96 mm



Max. X,Y:10° / Z:7mm



Sensor X,Y:1° / Z:0.7mm



Sensor 250V DC-100mA-NC



Max. 5 kg



0.1 to 300 mm

eBOT system for standard robots
with closed wrist and external
wiring to axis 6.

Anti-collision system for hollow shaft welding robots eBOT developed with the latest machining technology, the system gives maximum precision for the protection of your welding devices and can be adapted to any robot.

Advantages of eBOT anti-collision.

- They are compatible with all standard industrial wrist robots.
- Total protection of internal screws and sensors with IP64, prevents the accumulation of projections.
- 6 internal support points avoids zones of lower flexural strength improving the failure alarms due to inertias, this allows to increase the speed of movement of the robot.
- Manufactured in tempered steel and aeronautical aluminum 7075.
- Different levels of hardness to adapt to all applications

SPARE PARTS

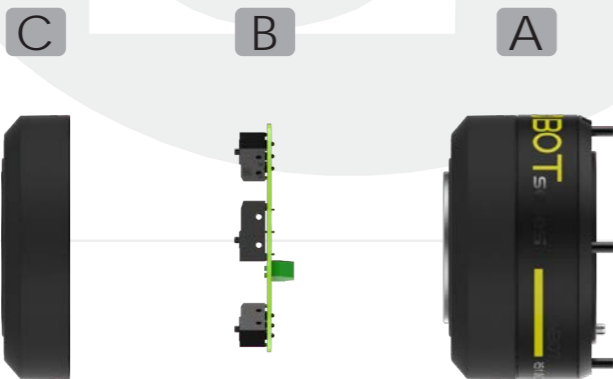

Pos.	TYPE	CODE	Min. Q.
A	Anti-collision eBOT medium	R53 0001	1
	Anti-collision eBOT high	R53 0002	1
B	Anti-collisi3n sensor BOT	R50 0014	1
C	Protection cover	R53 0011	1

SPARE PARTS

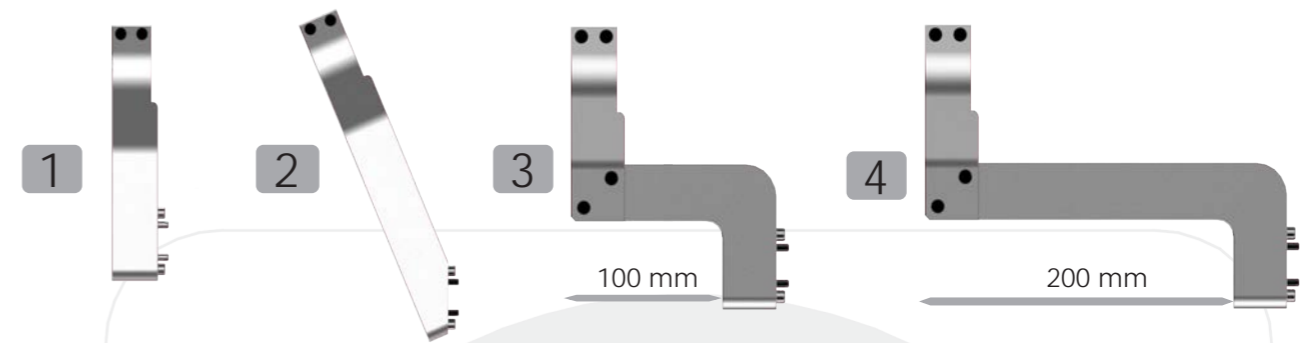

Pos.	TYPE	CODE	Min. Q.
1	Torch bracket eBOT 90°	R41 1000	1
2	Torch bracket eBOT 67°	R41 1023	1
3	Torch bracket eBOT 90°x100mm	R41 2100	bp
4	Torch bracket eBOT 90°x200mm	R41 2200	bp

STANDARD MEASURES

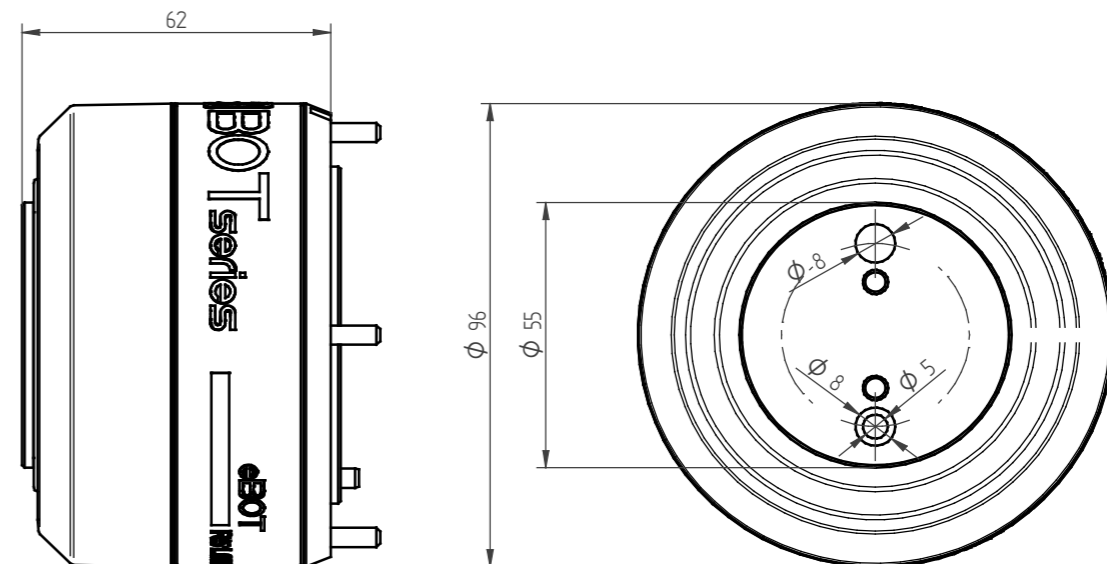

Adapter disc



Discs adapters to robots

Discs iBOT, eBOT, coBOT

48 Pag.



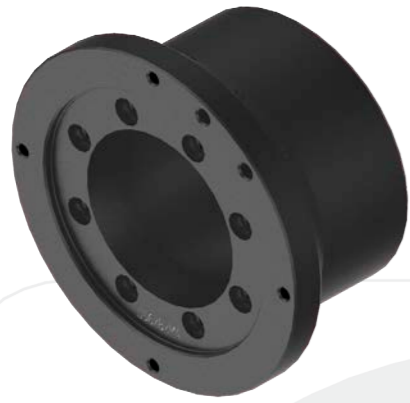

Welding process:
MIG/MAG, TIG
INDUSTRIAL ROBOTS



Compatible with BOT systems.



Adaptation to all welding robots.

The entire range of adaptation discs for fastening BOT welding systems to industrial robots, from conventional systems with closed disc to hollow shaft systems with open discs.

Welding systems for industrial robots BOTseries designed to last. Advantages BOT adapter discs.

- Precise adjustment for any industrial robot.
- Two manufacturing options in 7075 aeronautical aluminum or insulating materials for applications such as TIG or Plasma
- Possibility of manufacturing for robots of large non-specific welding dimensions, requesting prior study.
- Guide with pins that guarantee a correct position of the disc.

Type iBOT - Hollow shaft robots and internal wiring.

Type eBOT - Standard robots and external wiring.

Type eBASIC use without anti-collision system.

Type cBOT - Standard robots with hollow shaft wiring system

DISC TYPE

A

B

C

D



iBOT

iBOT

eBOT

eBASIC

Adapter disc measurements

Pos.		ROBOT TYPE	CODE	Min. Q.
C	FANUC	ARCMATE 100i	R73 0010	1
C	FANUC	ARCMATE 120iL	R73 0010	1
A	FANUC	ARCMATE 100iC	R71 0060L	1
A	FANUC	ARCMATE 100iD	R71 0061L	1
A	FANUC	ARCMATE 120iD	R71 0061L	1
C	ABB	IRB 1600	R73 0010	1
B	ABB	IRB 1600 ID	R71 0051	1
C	ABB	IRB 2400	R73 0030	1
C	ABB	IRB 2600	R73 0030	1
B	ABB	IRB 2600 ID	R71 0070	bp
B	PANASONIC	AW 1400	R71 0080	bp
C	KUKA	KR6	R73 0030	1
A	KUKA	KR6 R1820 arc HW	R71 0040L	1
A	KUKA	KR8 R1420 arc HW	R73 0040L	1
A	KUKA	KR8 R1620 arc HW	R71 0040L	1
A	KUKA	KR8 R2100 arc HW	R71 0040L	1
B	KUKA	KR16 HW	R71 0050	1
D	UR	UR3	R75 0020	1
D	UR	UR5	R75 0020	1
D	UR	UR10	R71 0020	1
C	MOTOMAN	UP-6	R73 0010	1
A	YASKAWA	MA1440	R71 0060L	1
A	YASKAWA	MA2010	R71 0060L	1
B	YASKAWA	MA1400	R71 0010	1
B	YASKAWA	MA1800	R71 0010	1
B	YASKAWA	MA1900	R71 0010	1

bp: product out of stock, manufacture on demand

Peripherals

5

Peripherals

TCP control BOT

52 Pag.

Cleaning station BOT

54 Pag.



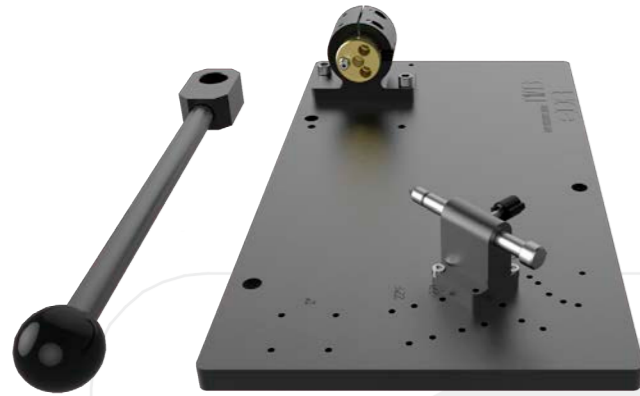

Welding process:
MIG/MAG,
Calibrated neck BOT series

- Max capacity of calibration + -2°
- Necks refrigerated liquid and gas

Calibration chart for MIG / MAG welding necks of the BOT series, allows for precise adjustment and calibration of the robotic necks, can for readjusting the neck after a blow or to verify its status after intensive use

Welding systems for industrial robots BOTseries designed to last. Advantages of the TCP control BOT.

- Rapid calibration of all necks of the BOT series.
- Multiple tools for each type of collar, avoiding damage with the calibration.
- Long lasting with steel construction with antioxidant treatment.

TYPE 1
Cod: R01 1000
Necks 30G, 40W, 41EC, 50W, 60W

TYPE 2
Cod: R01 2000
Necks 31W, 50WS

TYPE 3
Cod: R01 3000
Necks XXL

Maximum correction

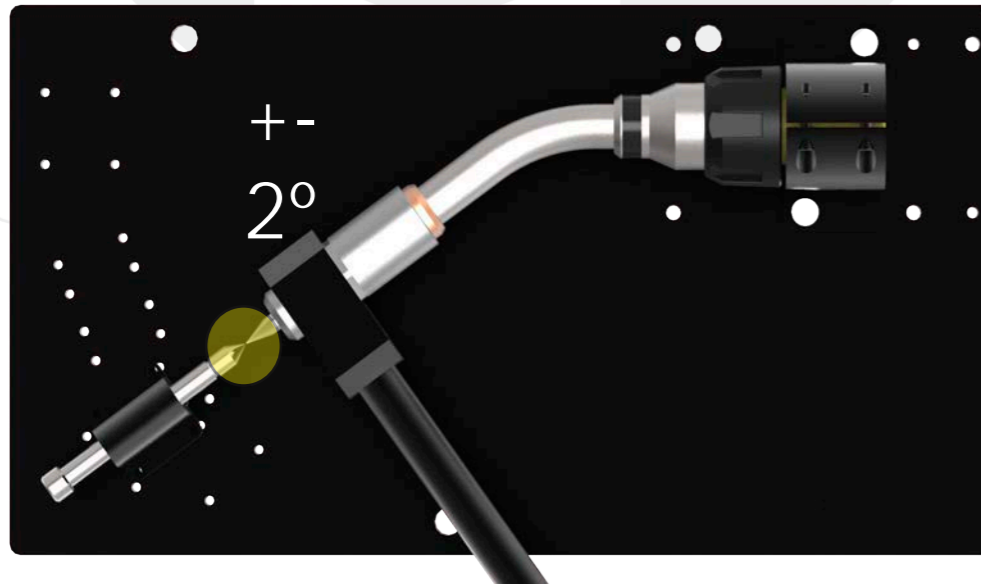

enDS-TCPCONTROL-02

Types

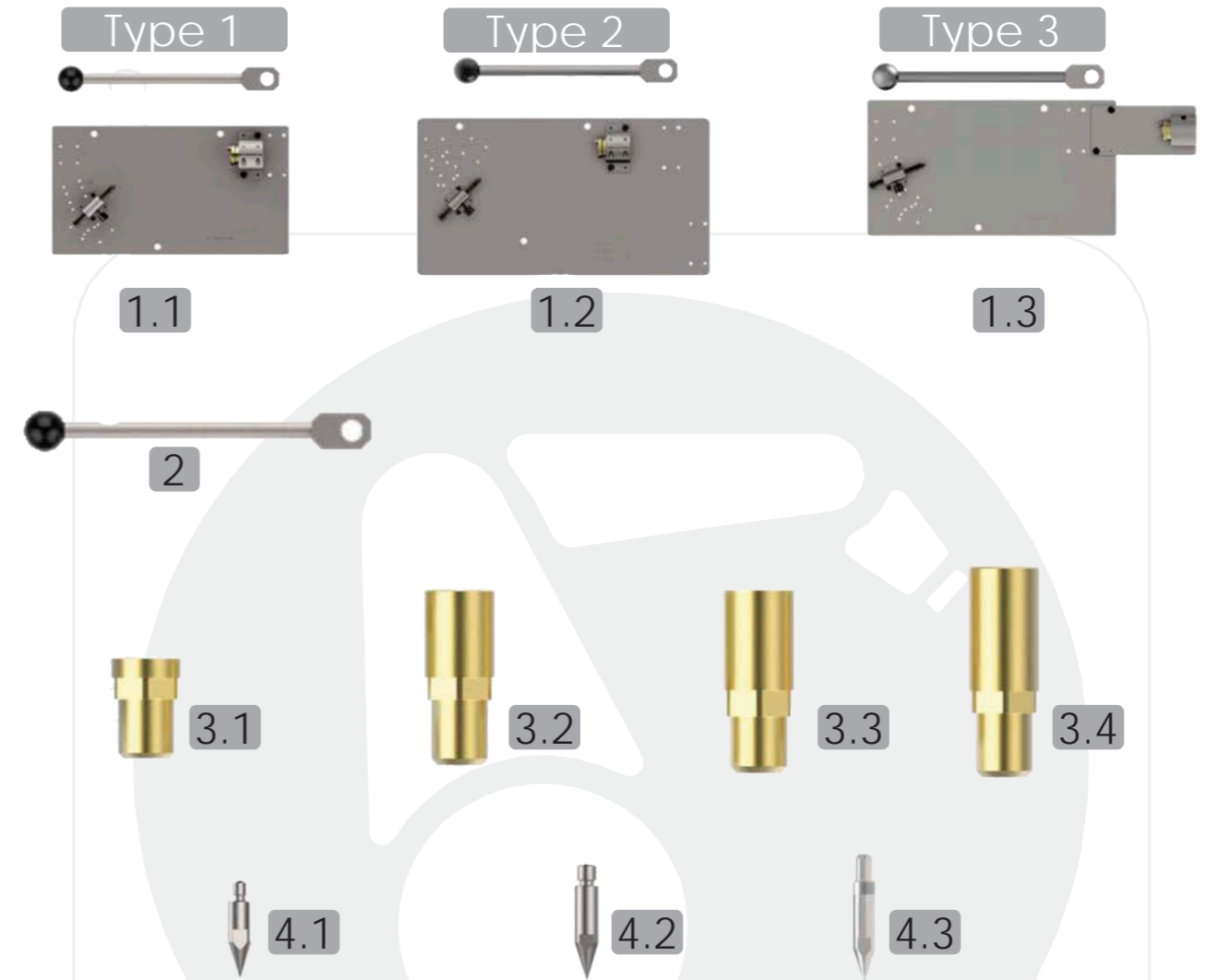

Pos.	ROBOT TYPE	CODE	Min. Q.
1.1	TCP control type 1	R01 1000	1
1.2	TCP control type 2	R01 2000	bp
1.3	TCP control type 3	R01 3000	bp
2	Correction lever	R01 0008	1
3.1	Check tool 31W	R02 0004	1
3.2	Check tool 30G/40W/41EC	R02 0001	1
3.3	Check tool 50W	R02 0005	1
3.4	Check tool 60W	R02 0006	1
4.1	Tip TCP M6-12mm-31W	R10 0312	1
4.2	Tip TCP EC M8-15mm-41EC	R10 0215	1
4.3	Tip TCP M10-15mm-30G-40W-50W-60W	R10 0115	1

bp: product out of stock, manufacture on demand

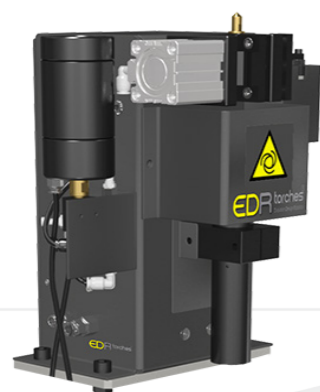

Welding process:
MIG/MAG,

- 6-8 bar *
- +5 - +50C°
- Min flow 10 l/s
- 6.3 Nm - 425 rpm
- 0.5 l spatter
- Max. 1.6 mm (solid wire)
- Max. 3.2 mm (tubular wire)
- Time cut 0.5 seg

(*) Oil-free compressed air

Nozzle cleaning station for automated and robotized welding torches. It incorporates welding wire cutting unit. Guarantees continuity of the welding process, keeping the nozzle of the welding torch free of slag and projections

- Main advantages:
- Elimination of cycle interruptions due to accumulation of projections.
 - Notable improvement of the initial priming efficiency while maintaining an optimum wire length
 - Cleaning efficiency, short cycle time.
 - Total elimination of embedded projections
 - Includes TCP programming verification point

Choose your reamer BOT series

BOT 30G 42G	Nozzle L76xD13mm	Nozzle L76xD15.5mm	Nozzle L79xD15.5mm
	R03 2041	R03 2040	R03 2061
BOT 31W	Nozzle L47xD13.5mm		
	R03 2030		
BOT 40W 52W	Nozzle L76xD13mm	Nozzle L76xD15.5mm	Nozzle L79xD15.5mm
	R03 2041	R03 2040	R03 2042
BOT 41EC	Nozzle L76xD15.5mm		
	R03 2010		
BOT 50W	Nozzle L60xD15.5mm	Nozzle L60xD18mm	
	R03 2040	R03 2050	
BOT 60W	Nozzle L16xD15.5mm	Nozzle L16xD18mm	Nozzle L16xD21mm
	R03 2061	R03 2060	R03 2062



A

Pos.	TYPE	CODE	Min. Q.
A	Clean station with wire cut (complete)	R02 2001	1

Reamer types for BOT series

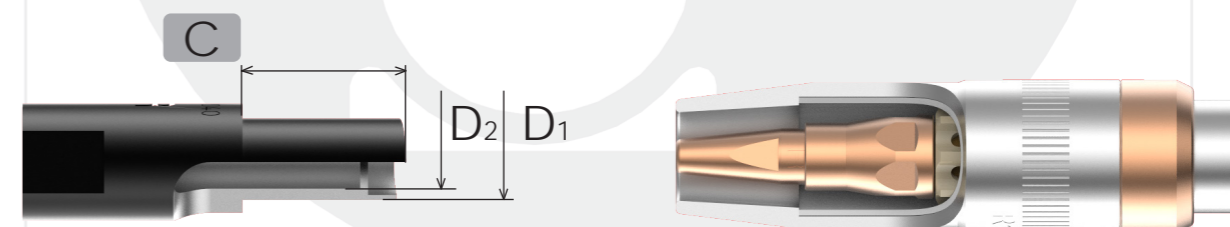

Pos.	TYPE	CODE	Min. Q.
C	Cleaning reamer TH L23xD13xD8.5 mm	R03 2030	1
	Cleaning reamer EC TH L38.5xD15xD10.5 mm	R03 2010	1
	Cleaning reamer TH L26xD15xD10.5 mm	R03 2040	1
	Cleaning reamer TH L22xD12.5xD10.5 mm	R03 2041	1
	Cleaning reamer TH L26xD17.5xD10.5 mm	R03 2050	1
	Cleaning reamer TH L29xD17.5xD10.5 mm	R03 2060	bp
	Cleaning reamer TH L29xD15xD10.5 mm	R03 2061	bp
	Cleaning reamer TH L29xD20.5xD10.5 mm	R03 2062	bp

bp: product out of stock, manufacture on demand

Spare parts

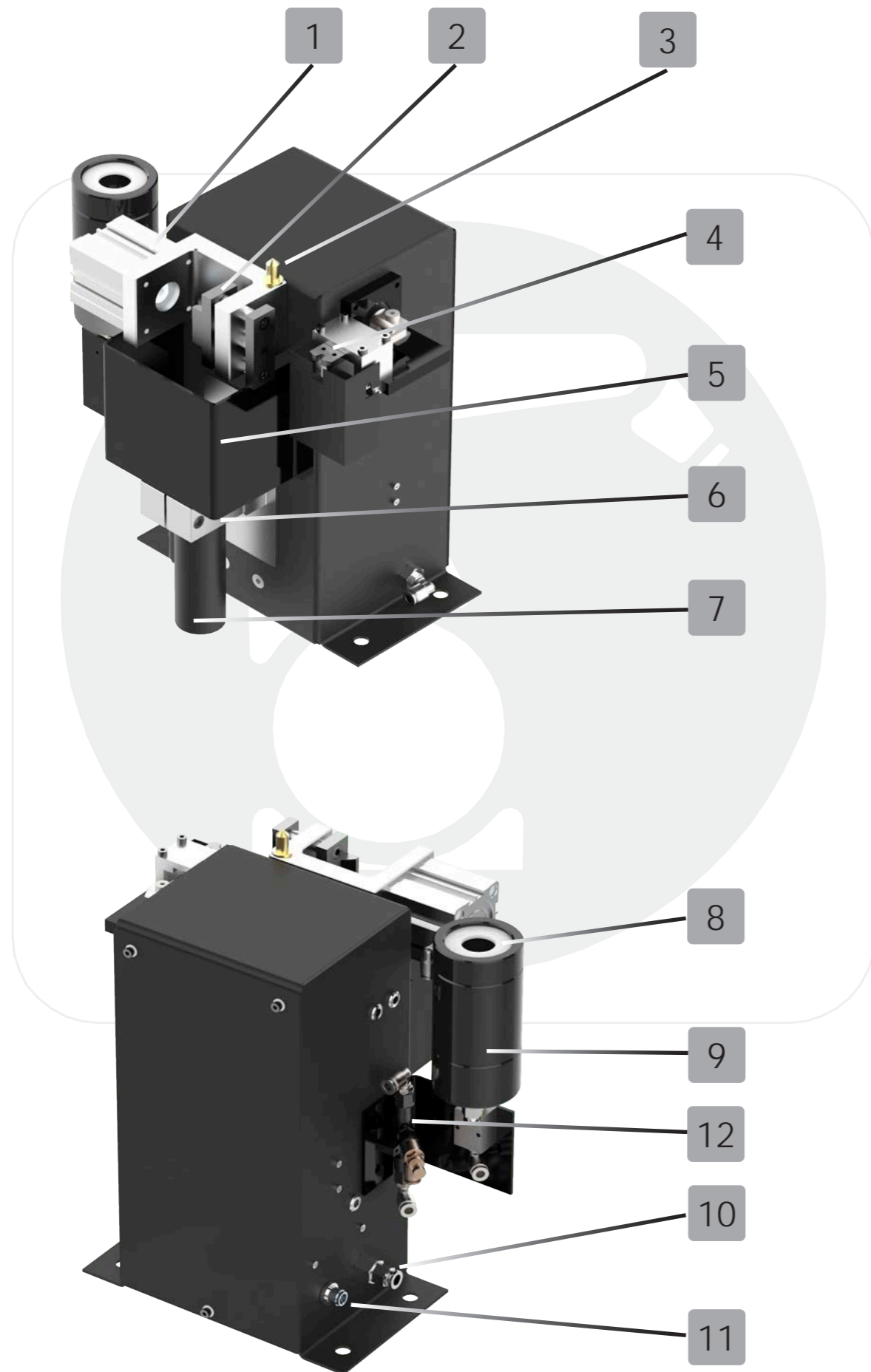

Pos.	Parts name	Functional descriptions	CODE	Min. Q.
1	Clamping cylinder	Automatic clamping welding nozzle	R02 2P01	1
2	Locator block	Fixing welding gun sprayer nozzle	R02 2P02	1
3	TCP positioning pin	TCP positioning points	R02 2P03	1
4	Wire shearing device	Wiping out needless welding wire	R02 2P04	1
5	Reamer protective cover	Preventing ejection of splash	R02 2P05	1
6	Motor mounting base	Adjusting height of pneumatic motor	R02 2P06	1
7	pneumatic motor	Driving reamer for cleaning	R02 2P07	1
8	Spray protector	Protect losses of liquid spray	R02 2P08	1
9	Anti-sling Unit	Spraying anti-sling agent	R02 2P09	1
10	Air connection port	Connecting 8mm air pipe	R02 2P10	1
11	8-pin Aviation plug	Controlling interface by robot	R02 2P11	1
12	Pneumatic distributor	Liquid control anti spatter	R02 2P12	1

Standard reamer types

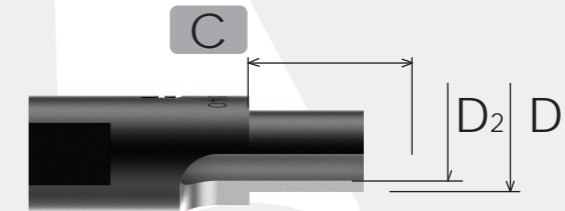

Nozzle Inner diameter mm	Nozzle Inner diameter mm	D1 mm	D2 mm	Code.	Min. Q.
10	6	9	7	R03 0907-40	bp
11	6	10	7	R03 1007-40	bp
12	6	11	7	R03 1107-40	bp
13	6	12	7	R03 1207-40	bp
13	8	12	9	R03 1209-40	bp
14	8	13	9	R03 1309-40	bp
15	8	14	9	R03 1409-40	bp
16	8	15	9	R03 1509-40	bp
13	9	12	10	R03 1210-40	bp
14	9	13	10	R03 1310-40	bp
15	9	14	10	R03 1410-40	bp
16	9	15	10	R03 1510-40	bp
15	10	14	11	R03 1411-40	bp
16	10	15	11	R03 1511-40	bp
17	10	16	11	R03 1611-40	bp
18	10	17	11	R03 1711-40	bp
18	12	17	13	R03 1713-40	bp
19	12	18	13	R03 1813-40	bp
20	12	19	13	R03 1913-40	bp

bp: product out of stock, manufacture on demand

Protective liquids

6

Protection

Coolant CLEAR PROTECT 10

59 Pag.

Anti-projection liquid SPATTER FREE 5

59 Pag.

Coolant CLEAR PROTECT 10 (10l)

Code: R07 0005



Anti-projection liquid SPATTER FREE 5 (5l)

Code: R07 1005





Annexes

7

Installations

Installation codes BOT-30G 62Pag.

Installation codes BOT-31W 64 Pag.

Installation codes BOT-41EC 66 Pag.

Installation codes BOT-40W 68 Pag.

Installation codes BOT-50W 70 Pag.

Installation codes BOT-60W 72 Pag.



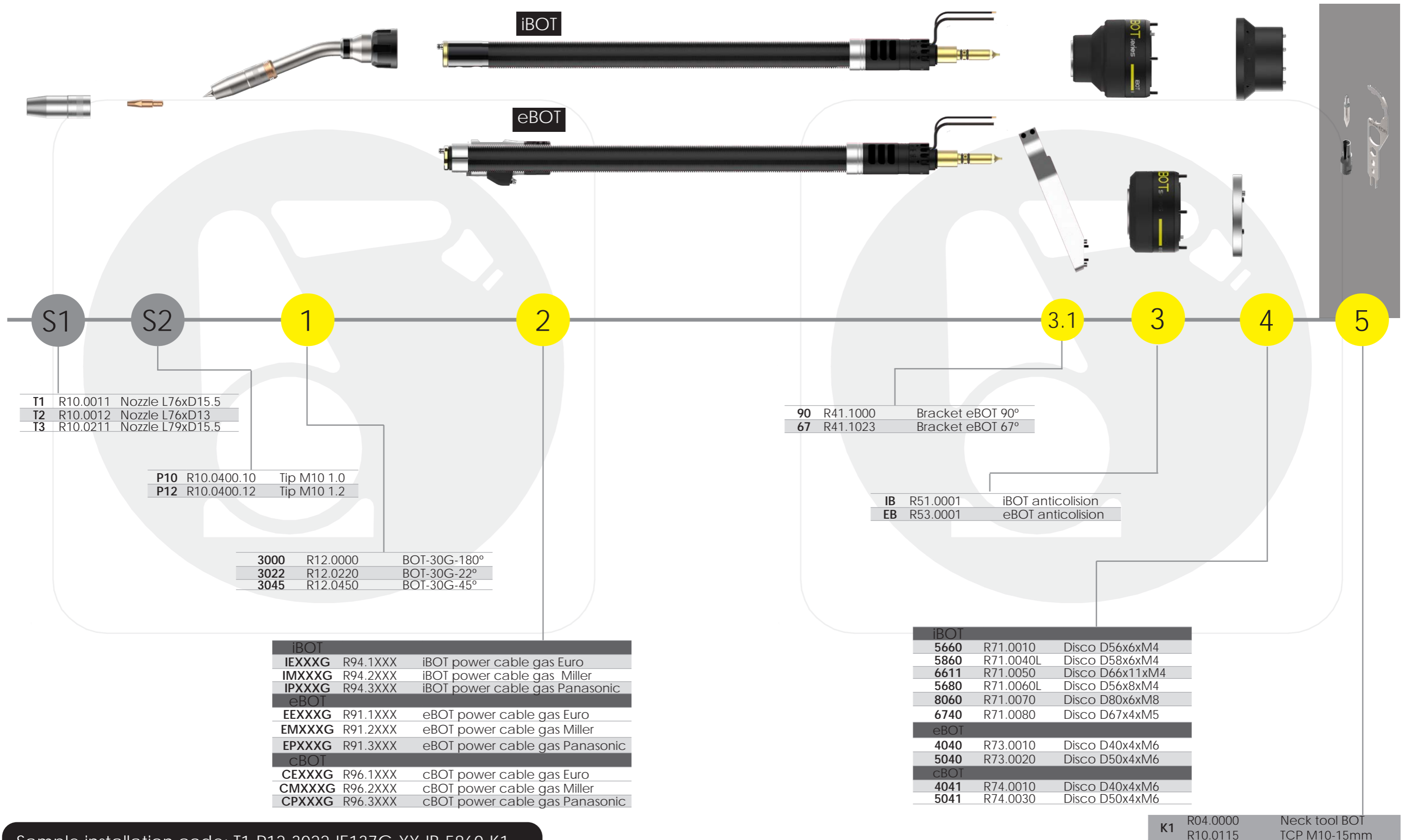

T1	R10.0011	Nozzle L76xD15.5
T2	R10.0012	Nozzle L76xD13
T3	R10.0211	Nozzle L79xD15.5

P10	R10.0400.10	Tip M10 1.0
P12	R10.0400.12	Tip M10 1.2

3000	R12.0000	BOT-30G-180°
3022	R12.0220	BOT-30G-22°
3045	R12.0450	BOT-30G-45°

90	R41.1000	Bracket eBOT 90°
67	R41.1023	Bracket eBOT 67°

IB	R51.0001	iBOT anticollision
EB	R53.0001	eBOT anticollision

iBOT		
IEXXXG	R94.1XXX	iBOT power cable gas Euro
IMXXXG	R94.2XXX	iBOT power cable gas Miller
IPXXXG	R94.3XXX	iBOT power cable gas Panasonic
eBOT		
EEXXXG	R91.1XXX	eBOT power cable gas Euro
EMXXXG	R91.2XXX	eBOT power cable gas Miller
EPXXXG	R91.3XXX	eBOT power cable gas Panasonic
cBOT		
CEXXXG	R96.1XXX	cBOT power cable gas Euro
CMXXXG	R96.2XXX	cBOT power cable gas Miller
CPXXXG	R96.3XXX	cBOT power cable gas Panasonic

iBOT		
5660	R71.0010	Disco D56x6xM4
5860	R71.0040L	Disco D58x6xM4
6611	R71.0050	Disco D66x11xM4
5680	R71.0060L	Disco D56x8xM4
8060	R71.0070	Disco D80x6xM8
6740	R71.0080	Disco D67x4xM5
eBOT		
4040	R73.0010	Disco D40x4xM6
5040	R73.0020	Disco D50x4xM6
cBOT		
4041	R74.0010	Disco D40x4xM6
5041	R74.0030	Disco D50x4xM6

K1	R04.0000	Neck tool BOT
	R10.0115	TCP M10-15mm

Sample installation code: T1-P12-3022-IE137G-XX-IB-5860-K1

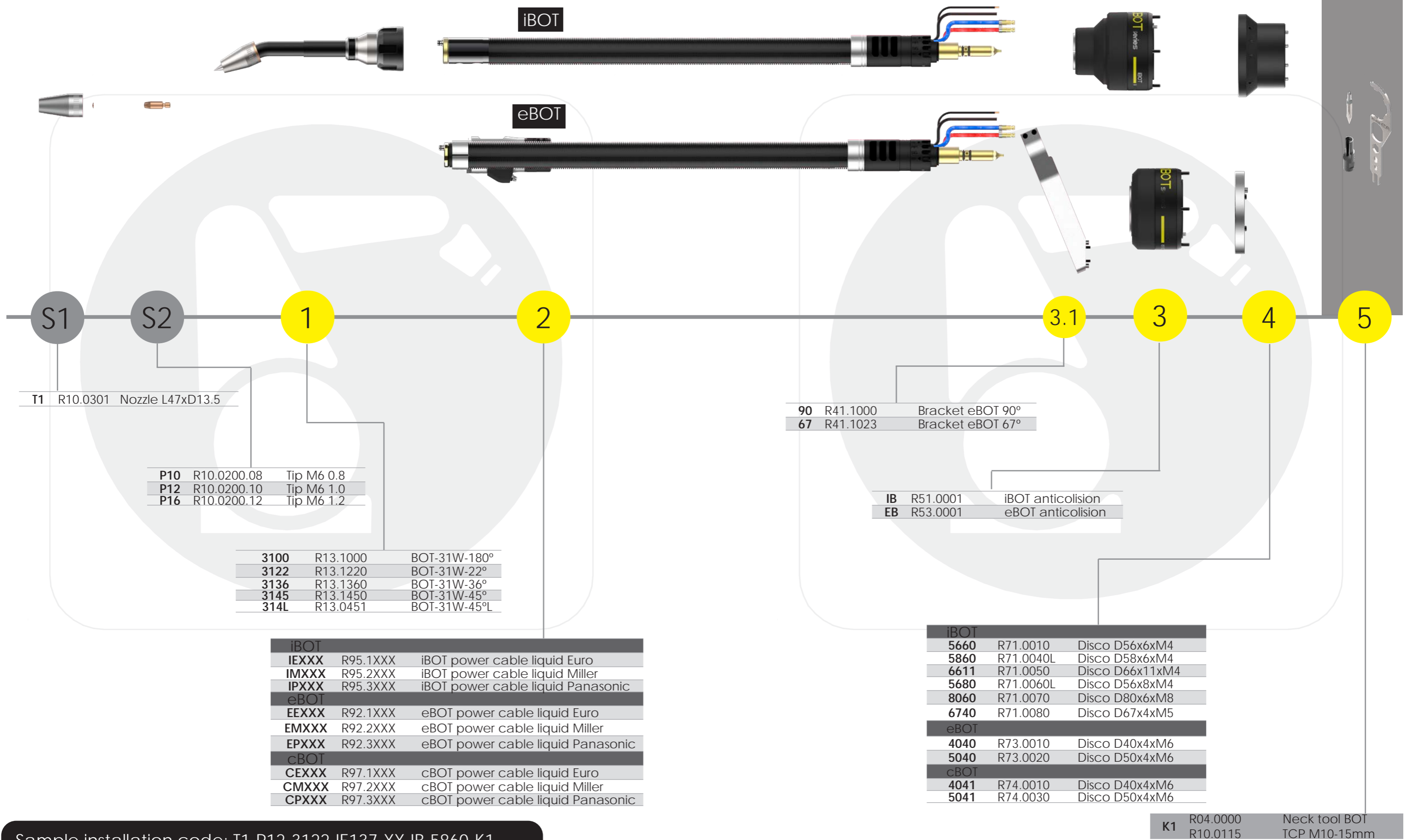

T1 R10.0301 Nozzle L47xD13.5

P10 R10.0200.08 Tip M6 0.8
 P12 R10.0200.10 Tip M6 1.0
 P16 R10.0200.12 Tip M6 1.2

3100 R13.1000 BOT-31W-180°
 3122 R13.1220 BOT-31W-22°
 3136 R13.1360 BOT-31W-36°
 3145 R13.1450 BOT-31W-45°
 314L R13.0451 BOT-31W-45°L

90 R41.1000 Bracket eBOT 90°
 67 R41.1023 Bracket eBOT 67°

IB R51.0001 iBOT anticollision
 EB R53.0001 eBOT anticollision

iBOT		
IEXXX	R95.1XXX	iBOT power cable liquid Euro
IMXXX	R95.2XXX	iBOT power cable liquid Miller
IPXXX	R95.3XXX	iBOT power cable liquid Panasonic
eBOT		
EEXXX	R92.1XXX	eBOT power cable liquid Euro
EMXXX	R92.2XXX	eBOT power cable liquid Miller
EPXXX	R92.3XXX	eBOT power cable liquid Panasonic
cBOT		
CEXXX	R97.1XXX	cBOT power cable liquid Euro
CMXXX	R97.2XXX	cBOT power cable liquid Miller
CPXXX	R97.3XXX	cBOT power cable liquid Panasonic

iBOT		
5660	R71.0010	Disco D56x6xM4
5860	R71.0040L	Disco D58x6xM4
6611	R71.0050	Disco D66x11xM4
5680	R71.0060L	Disco D56x8xM4
8060	R71.0070	Disco D80x6xM8
6740	R71.0080	Disco D67x4xM5
eBOT		
4040	R73.0010	Disco D40x4xM6
5040	R73.0020	Disco D50x4xM6
cBOT		
4041	R74.0010	Disco D40x4xM6
5041	R74.0030	Disco D50x4xM6

K1 R04.0000 Neck tool BOT
 R10.0115 TCP M10-15mm

Sample installation code: T1-P12-3122-IE137-XX-IB-5860-K1

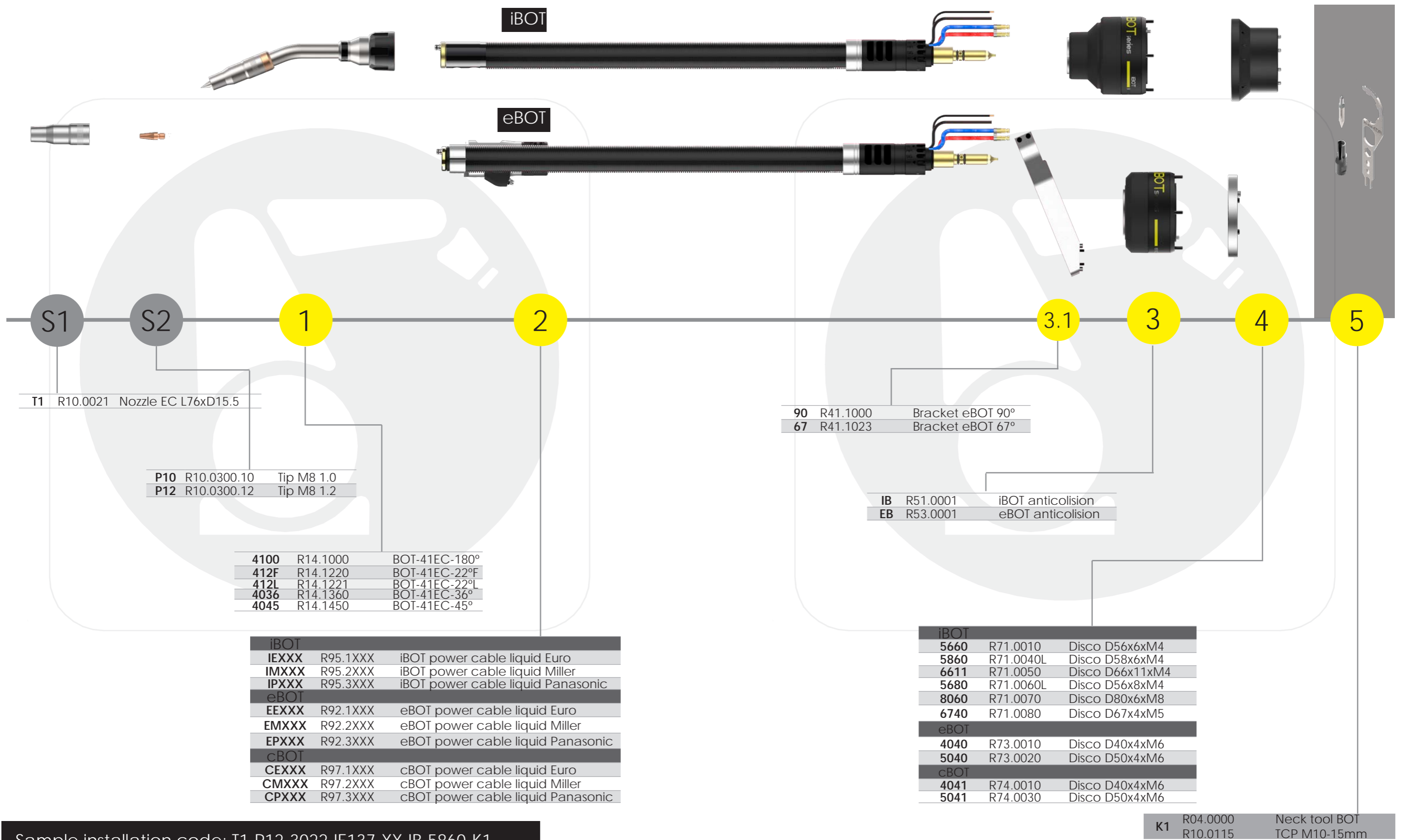

T1 R10.0021 Nozzle EC L76xD15.5

P10 R10.0300.10 Tip M8 1.0
P12 R10.0300.12 Tip M8 1.2

4100 R14.1000 BOT-41EC-180°
412F R14.1220 BOT-41EC-22°F
412L R14.1221 BOT-41EC-22°L
4036 R14.1360 BOT-41EC-36°
4045 R14.1450 BOT-41EC-45°

90 R41.1000 Bracket eBOT 90°
67 R41.1023 Bracket eBOT 67°

IB R51.0001 iBOT anticollision
EB R53.0001 eBOT anticollision

iBOT		
IEXXX	R95.1XXX	iBOT power cable liquid Euro
IMXXX	R95.2XXX	iBOT power cable liquid Miller
IPXXX	R95.3XXX	iBOT power cable liquid Panasonic
eBOT		
EEXXX	R92.1XXX	eBOT power cable liquid Euro
EMXXX	R92.2XXX	eBOT power cable liquid Miller
EPXXX	R92.3XXX	eBOT power cable liquid Panasonic
cBOT		
CExXX	R97.1XXX	cBOT power cable liquid Euro
CMXXX	R97.2XXX	cBOT power cable liquid Miller
CPXXX	R97.3XXX	cBOT power cable liquid Panasonic

iBOT		
5660	R71.0010	Disco D56x6xM4
5860	R71.0040L	Disco D58x6xM4
6611	R71.0050	Disco D66x11xM4
5680	R71.0060L	Disco D56x8xM4
8060	R71.0070	Disco D80x6xM8
6740	R71.0080	Disco D67x4xM5
eBOT		
4040	R73.0010	Disco D40x4xM6
5040	R73.0020	Disco D50x4xM6
cBOT		
4041	R74.0010	Disco D40x4xM6
5041	R74.0030	Disco D50x4xM6

K1 R04.0000 Neck tool BOT
R10.0115 TCP M10-15mm

Sample installation code: T1-P12-3022-IE137-XX-IB-5860-K1

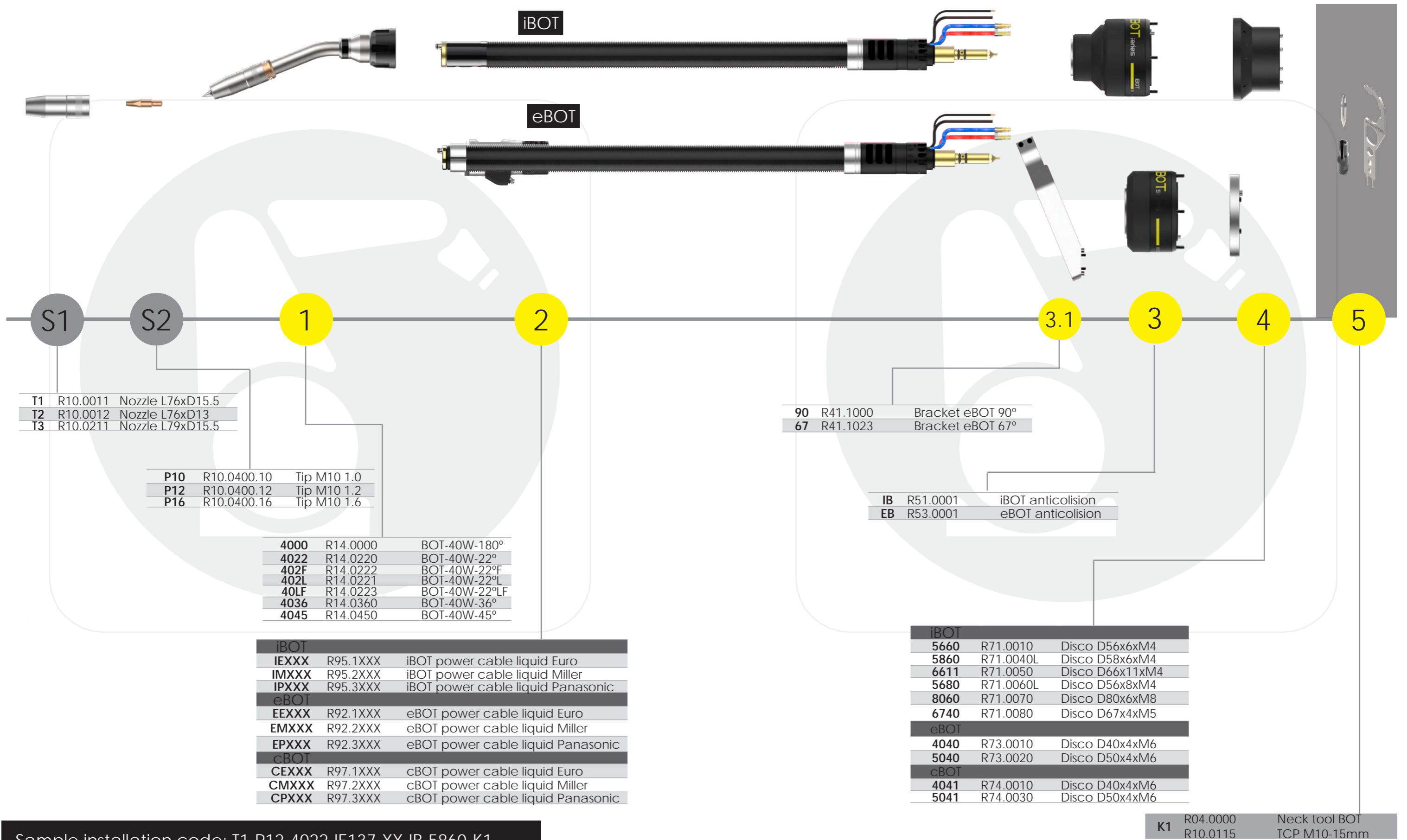

T1	R10.0011	Nozzle L76xD15.5
T2	R10.0012	Nozzle L76xD13
T3	R10.0211	Nozzle L79xD15.5

P10	R10.0400.10	Tip M10 1.0
P12	R10.0400.12	Tip M10 1.2
P16	R10.0400.16	Tip M10 1.6

4000	R14.0000	BOT-40W-180°
4022	R14.0220	BOT-40W-22°
402F	R14.0222	BOT-40W-22°F
402L	R14.0221	BOT-40W-22°L
40LF	R14.0223	BOT-40W-22°LF
4036	R14.0360	BOT-40W-36°
4045	R14.0450	BOT-40W-45°

iBOT		
IEXXX	R95.1XXX	iBOT power cable liquid Euro
IMXXX	R95.2XXX	iBOT power cable liquid Miller
IPXXX	R95.3XXX	iBOT power cable liquid Panasonic
eBOT		
EEXXX	R92.1XXX	eBOT power cable liquid Euro
EMXXX	R92.2XXX	eBOT power cable liquid Miller
EPXXX	R92.3XXX	eBOT power cable liquid Panasonic
cBOT		
CExXX	R97.1XXX	cBOT power cable liquid Euro
CMXXX	R97.2XXX	cBOT power cable liquid Miller
CPXXX	R97.3XXX	cBOT power cable liquid Panasonic

90	R41.1000	Bracket eBOT 90°
67	R41.1023	Bracket eBOT 67°

IB	R51.0001	iBOT anticollision
EB	R53.0001	eBOT anticollision

iBOT		
5660	R71.0010	Disco D56x6xM4
5860	R71.0040L	Disco D58x6xM4
6611	R71.0050	Disco D66x11xM4
5680	R71.0060L	Disco D56x8xM4
8060	R71.0070	Disco D80x6xM8
6740	R71.0080	Disco D67x4xM5
eBOT		
4040	R73.0010	Disco D40x4xM6
5040	R73.0020	Disco D50x4xM6
cBOT		
4041	R74.0010	Disco D40x4xM6
5041	R74.0030	Disco D50x4xM6

K1	R04.0000	Neck tool BOT
	R10.0115	TCP M10-15mm

Sample installation code: T1-P12-4022-IE137-XX-IB-5860-K1

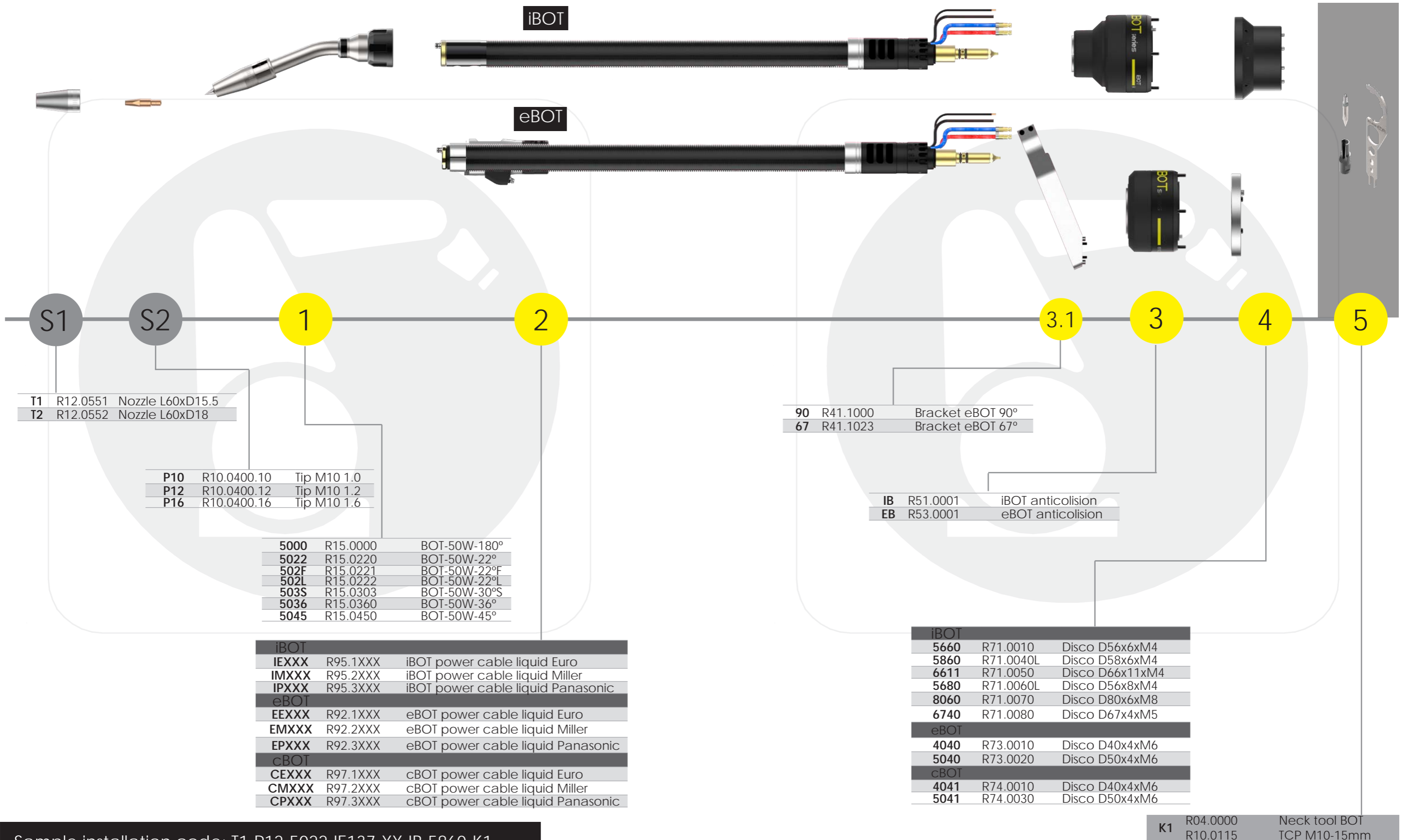

T1	R12.0551	Nozzle L60xD15.5
T2	R12.0552	Nozzle L60xD18

P10	R10.0400.10	Tip M10 1.0
P12	R10.0400.12	Tip M10 1.2
P16	R10.0400.16	Tip M10 1.6

5000	R15.0000	BOT-50W-180°
5022	R15.0220	BOT-50W-22°
502F	R15.0221	BOT-50W-22°F
502L	R15.0222	BOT-50W-22°L
503S	R15.0303	BOT-50W-30°S
5036	R15.0360	BOT-50W-36°
5045	R15.0450	BOT-50W-45°

iBOT		
IEXXX	R95.1XXX	iBOT power cable liquid Euro
IMXXX	R95.2XXX	iBOT power cable liquid Miller
IPXXX	R95.3XXX	iBOT power cable liquid Panasonic
eBOT		
EEXXX	R92.1XXX	eBOT power cable liquid Euro
EMXXX	R92.2XXX	eBOT power cable liquid Miller
EPXXX	R92.3XXX	eBOT power cable liquid Panasonic
cBOT		
CEXXX	R97.1XXX	cBOT power cable liquid Euro
CMXXX	R97.2XXX	cBOT power cable liquid Miller
CPXXX	R97.3XXX	cBOT power cable liquid Panasonic

90	R41.1000	Bracket eBOT 90°
67	R41.1023	Bracket eBOT 67°

IB	R51.0001	iBOT anticollision
EB	R53.0001	eBOT anticollision

iBOT		
5660	R71.0010	Disco D56x6xM4
5860	R71.0040L	Disco D58x6xM4
6611	R71.0050	Disco D66x11xM4
5680	R71.0060L	Disco D56x8xM4
8060	R71.0070	Disco D80x6xM8
6740	R71.0080	Disco D67x4xM5
eBOT		
4040	R73.0010	Disco D40x4xM6
5040	R73.0020	Disco D50x4xM6
cBOT		
4041	R74.0010	Disco D40x4xM6
5041	R74.0030	Disco D50x4xM6

K1	R04.0000	Neck tool BOT
	R10.0115	TCP M10-15mm

Sample installation code: T1-P12-5022-IE137-XX-IB-5860-K1

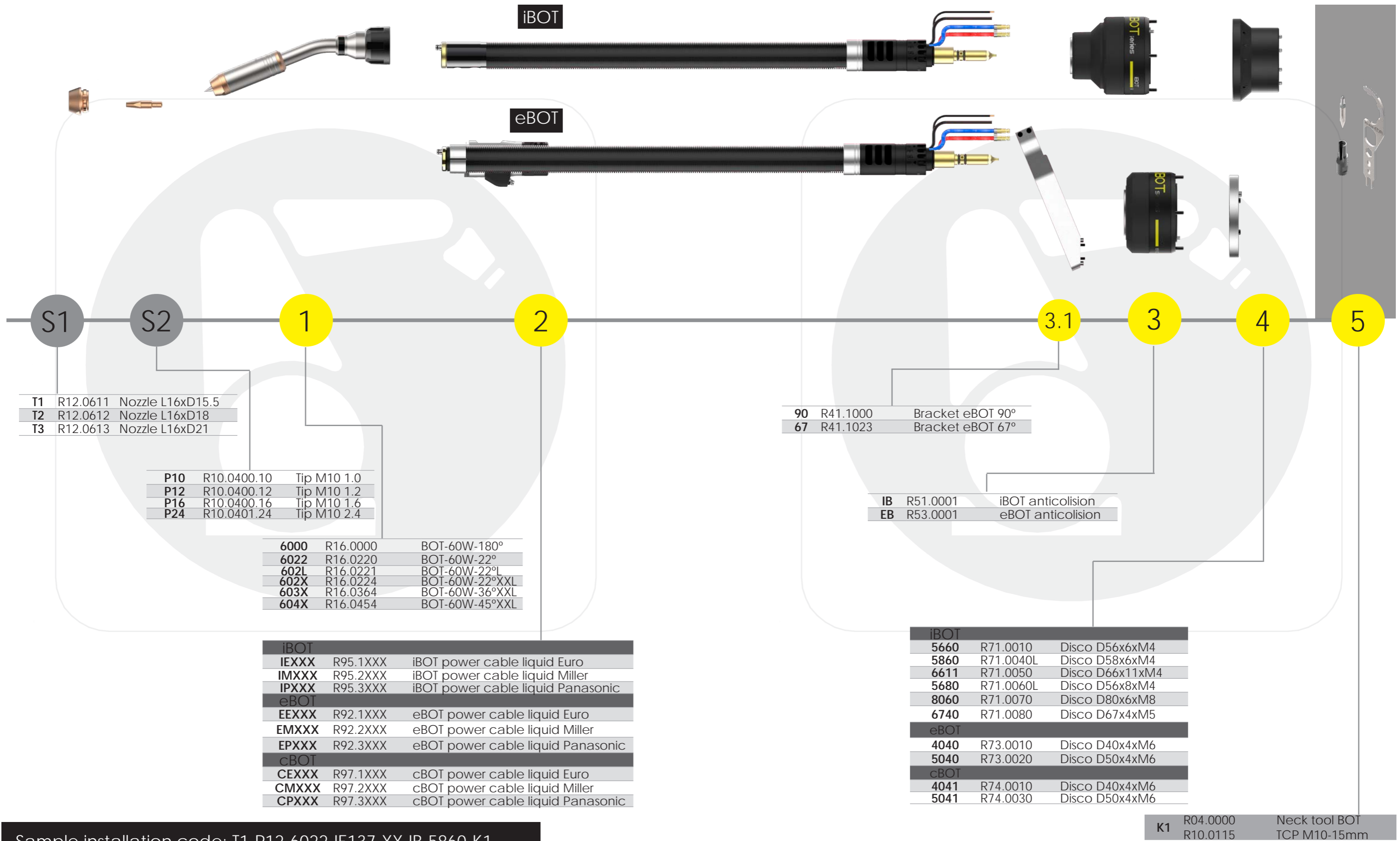

T1	R12.0611	Nozzle L16xD15.5
T2	R12.0612	Nozzle L16xD18
T3	R12.0613	Nozzle L16xD21

P10	R10.0400.10	Tip M10 1.0
P12	R10.0400.12	Tip M10 1.2
P16	R10.0400.16	Tip M10 1.6
P24	R10.0401.24	Tip M10 2.4

6000	R16.0000	BOT-60W-180°
6022	R16.0220	BOT-60W-22°
602L	R16.0221	BOT-60W-22°L
602X	R16.0224	BOT-60W-22°XXL
603X	R16.0364	BOT-60W-36°XXL
604X	R16.0454	BOT-60W-45°XXL

iBOT		
IEXXX	R95.1XXX	iBOT power cable liquid Euro
IMXXX	R95.2XXX	iBOT power cable liquid Miller
IPXXX	R95.3XXX	iBOT power cable liquid Panasonic
eBOT		
EEXXX	R92.1XXX	eBOT power cable liquid Euro
EMXXX	R92.2XXX	eBOT power cable liquid Miller
EPXXX	R92.3XXX	eBOT power cable liquid Panasonic
cBOT		
CEXXX	R97.1XXX	cBOT power cable liquid Euro
CMXXX	R97.2XXX	cBOT power cable liquid Miller
CPXXX	R97.3XXX	cBOT power cable liquid Panasonic

90	R41.1000	Bracket eBOT 90°
67	R41.1023	Bracket eBOT 67°

IB	R51.0001	iBOT anticollision
EB	R53.0001	eBOT anticollision

iBOT		
5660	R71.0010	Disco D56x6xM4
5860	R71.0040L	Disco D58x6xM4
6611	R71.0050	Disco D66x11xM4
5680	R71.0060L	Disco D56x8xM4
8060	R71.0070	Disco D80x6xM8
6740	R71.0080	Disco D67x4xM5
eBOT		
4040	R73.0010	Disco D40x4xM6
5040	R73.0020	Disco D50x4xM6
cBOT		
4041	R74.0010	Disco D40x4xM6
5041	R74.0030	Disco D50x4xM6

K1	R04.0000	Neck tool BOT
	R10.0115	TCP M10-15mm

Sample installation code: T1-P12-6022-IE137-XX-IB-5860-K1

Robotic welding torches



EDRtorches, S.L.
Calle Miguel Angel Blanco 28. 46138
Rafelbuñol - Valencia Spain.
www.edrtorches.com
info@edrtorches.com
Tel. 0034 963 558 893