

**bercoweld<sup>®</sup>**

wire solutions for brazing and welding

**bedra**  
intelligent wires



## Filler metals for brazing and welding made of copper and copper alloys

### bercoweld® from bedra.

With a tradition spanning more than 125 years, bedra has become synonymous with innovative high-tech precision wires made in Germany. We serve customers around the world in the brazing and welding technology as well as EDM, electronics and specialty applications from our two German factories.

With **bercoweld®** we have developed wire electrodes especially designed for the brazing and welding technology industries.

We are the only manufacturer of precision wires to offer the entire production chain - from melting to final packaging - from a single source.

The established bedra in-house concept also includes our own foundry. It goes without saying that only virgin metals are used for the production of **bercoweld®**.

Thus, bedra customers will acquire wire electrodes of outstanding quality ensuring reliable processing and complete traceability.

### You can rely on it

Strict quality assurance guarantees the reliability of our products: bedra precision wires are produced under a certified QM system acc. to DIN EN ISO 9001. Our Environmental Management System is certified acc. to DIN EN ISO 14001.



- In the bedra own foundry, bercoweld® wires are produced while adhering to tightest alloy tolerances



### Your benefits at a glance:

- Material closure joints
- Good gap bridging
- High corrosion resistance



■ Automotive industry



■ Rail vehicles



■ Plant engineering

Some examples of the wide range of **bercoweld®** applications.

### **bercoweld® in detail**

The appropriate product for every application: Our **bercoweld®** range currently comprises more than 20 alloys of the following material groups

- low-alloyed copper alloys
- tin-bronzes
- aluminium-bronzes
- copper-nickel-alloys
- special alloys

### **bercoweld® in application**

Be it MIG/MAG brazing or welding, TIG welding, laser and plasma brazing or flame spraying: **bercoweld®** wire electrodes are as varied as their range of applications, be it in the automotive industry, track and railroad car construction, plant engineering, offshore or onshore, **bercoweld®** is always an integral part of innovative joining technologies.

### **bercoweld® on the move**

The automotive sector represents a major application area for **bercoweld®**. Applications such as tailormade body blanks of thin sheets in different qualities are laser-welded, low or high-temperature brazed with **bercoweld®**.

All renowned automobile manufacturers worldwide rely on **bercoweld®** wire electrodes from bedra.

## Product range

Material	bedra alloy	Standard designation	Composition (weight %)								
			Cu	Al	Si	Sn	Mn	Ni	P	Fe	Others
Low alloyed copper materials	<b>bercoweld K3</b> (SF-Cu)	not standardized	balance							0.05	
	<b>bercoweld K5</b> (CSSM)	Cu1898 (ISO 24373) SG-CuSn (DIN 1733) ERCu (AWS A5.7-84)	balance		0.2	0.8	0.2			0.01	max. 0.5
	<b>bercoweld S3</b> (CuSi3Mn)	Cu6560 (ISO 24373) SG-CuSi3 (DIN 1733) ERCuSi-A (AWS A5.7-84)	balance		2.9		0.9				max. 0.5
	<b>bercoweld S2</b> (COMAS)	Cu6511 (ISO 24373)	balance		1.8	0.2	1.0			0.01	
	<b>bercoweld K8/K9</b> (CuAg/W/G)	Cu1897 (ISO 24373) SG-CuAg (DIN 1733)	balance				0.1			0.01	max. 0.5
Tin bronzes	<b>bercoweld B6</b> (BI66)	Cu5180 (ISO 24373) SG-CuSn6 (DIN 1733) ERCuSn-A (AWS A5.7-84)	balance			6.5				0.25	max. 0.5
	<b>bercoweld B8</b> (BI80)	Cu5210 (ISO 24373) SG-CuSn6 (DIN 1733) ERCuSn-C (AWS A5.6-84)	balance			8.0				0.1	max. 0.5
	<b>bercoweld B60</b> (BS60)	not standardized	balance		0.25	6.0	0.25				max. 0.5
	<b>bercoweld B10</b> (BS100)	Cu5211 (ISO 24373)	balance		0.25	9.5	0.25				max. 0.5
	<b>bercoweld B12</b> (B130)	Cu5410 (ISO 24373)	balance			13.0				0.2	max. 0.5
Aluminium bronzes	<b>bercoweld A52</b> (AIBz5Ni2)	Cu6061 (ISO 24373)	balance	5.0			0.2	2.0			max. 0.5
	<b>bercoweld A8</b> (AIBz8)	Cu6100 (ISO 24373) SG-CuAl8 (DIN 1733) ERCuAl-A1 (AWS A5.7-84)	balance	8.0							
	<b>bercoweld A822</b> (AIBz8MNF)	Cu6327 (ISO 24373) SG-CuAl8Ni2 (DIN 1733)	balance	8.0			2.0	2.0		2.0	max. 0.5
	<b>bercoweld A9</b> (AIBz9Fe)	Cu6180 (ISO 24373) SG-CuAl10Fe (DIN 1733) ERCuAl-A2 (AWS A5.7-84)	balance	9.5						1,2	max. 0.5
	<b>bercoweld A922</b> (AIBz9Ni)	Cu6327 (ISO 24373) SG-CuAl8Ni2 (DIN 1733)	balance	9,0			2.0	2.5		1.5	max. 0.5
	<b>bercoweld A35</b> (AIBz35)	Cu6328 (ISO 24373) SG-CuAl9Ni5 (DIN 1733) ERCuNiAl (AWS A5.7-84)	balance	9.0			1.5	5.0		3.5	max. 0.5
	<b>bercoweld A300</b> (MAXAL300)	Cu6331 (ISO 24373) SG-CuMn13Al7 (DIN 1733) ERCuMnNiAl (AWS A5.7-84)	balance	8.0			13.0	2.5		2.5	max. 0.5
Copper-nickel alloys	<b>bercoweld N10</b> (CuNi10Fe)	Cu7061 (ISO 24373) SG-CuNi10Fe (DIN 1733)	balance				1.0	10.5		1.5	max. 0.5 Ti 0,4
	<b>bercoweld N30</b> (CuNi30Fe)	Cu7158 (ISO 24373) SG-CuNi30Fe (DIN 1733) ERCuNi (AWS A5.7-84)	balance				1.0	31.0		0.5	max. 0.5 Ti 0.4
Special alloys	<b>bercoweld K1</b> (E-Cu58)	not standardized	99.90								max.0,1
	<b>bercoweld K2</b> (OF-Cu)	not standardized	99.99								max.0.01
	<b>bercoweld M122</b> (CuMn12Ni2)	not standardized	balance				12	2			max.0.5

Other special alloys on request

Calculation of running length (as an example for the bercoweld® alloys S3 and A8):

		15 kg spool				200 kg drum/wooden spool		
Wire diameter in mm		0,8	1	1,2	1,6	1	1,2	1,6
Product	Density kg/dm <sup>3</sup>	approx. wire length in meter				approx. wire length in meter		
S3	8,5	3.515	2.248	1.564	878	29.974	20.815	11.709
A8	7,7	3.877	2.482	1.723	969	33.088	22.978	12.925

Physical properties of the materials						Mechanical properties of the weld joint, standard data			
Density kg / dm <sup>3</sup>	Melting range °C	Thermal conductivity W/m · K	Coefficient of thermal expansion 10 <sup>-6</sup> /K	Electric conductivity S · m/mm <sup>2</sup>	IACS %	Tensile strength N/mm <sup>2</sup>	Elongation %	Brinell hardness HB 2.5 / 62.5	Notched bar impact test Av(7)
8.9	~ 1080	293-364	17.0	41-52	~70-89	220	40	50	65
8.9	1020-1050	120-145	18.1	15-20	~26-34	220	30	60	75
8.5	965-1035	35	18.1	3.5-4.0	~6-7	350	40	80	60
8.7	1030-1050	40	18.1	4.7-5.3	~8-9	285	45	62	75
8.9	1070-1080	220-315	17.7	44-46	~70-80	200	30	60	75
8.7	910-1040	75	18.1	6-7	~10-12	260	20	80	32
8.8	875-1025	67	18.5	6-8	~10-14	260	20	80	32
8.8	900-1040	62	18.4	7.3-7.9	~12-14	359	44	101	68
8.7	887-1020	47	18.0	5-6	~9-10	290	14	115	24
8.6	825-990	40-50	18.5	3-5	~5-9	320	5	120	8
8.2	1060-1085	61	17.5	8-8.8	~14-15	353	45	84	161
7.7	1030-1040	65	17.0	7-9	~12-15	430	40	100	100
7.5	1030-1050	50	17.0	4.5-5.5	~8-9	530	30	140	70
7.6	1030-1040	55	16,5	6.5-7.5	~11-13	500	35	140	95
7.5	1030-1050	50	17.0	4.5-5.5	~8-9	530	30	150	70
7.5	1015-1045	20-40	19.3	3-4	~5-7	690	16	min. 200	68
7.4	945-985	30	21.5	3-5	~5-9	900	10	290	180
8.9	1100-1145	30	17.0	2.8-3.2	~5-6	300	34	80	190
8.9	1180-1240	30	17.3	2.7-3.3	~5-6	420	36	115	240
8.93	1083	394	17.3	58.6	100	200	40	50	60
8.93	1083	394	17.3	58.6	100	200	40	50	60
8.4	950-970	22	18.3	2.2-2.4	~3-4	400	40	100	100



## Product details & applications

Oxygen-free special copper wire. Joining of grey cast iron and steel, copper-to-copper joining.

Sn-alloyed copper wire. Especially suited for joining and overlay welding on copper; joining of grey cast iron and steels possible, joining of zinc-coated sheets.

Zinc-coated car body sheets in the automotive industry, overlay welding on low-alloyed steels, solenoid valves, control cabinets.

Specifically developed material with reduced Si-content for brazing of zinc-coated sheets, better flowing properties than S3.

Copper-silver material. Particularly suitable for joining and overlay welding on copper; for large workpieces preheating to approx. 450°C is recommended.

Repairs to large copper parts or bronzes, furnace soldering, solenoid valves, heat exchangers, slide rails, bearing bushes.

Repairs to bronzes. Furnace brazing, solenoid valves. Also suited for zinc-coated sheets, slide rails and bearing bushes.

Specifically developed alloy for zinc-coated sheets in the automotive industry.

Specifically developed alloy for zinc-coated sheets in the automotive industry.

Welding of copper materials of any kind. Overlay welding on bearing bushes, slide rails. Highest hardness for bronzes.

Specifically developed alloy for joining zinc-coated sheets and ferritic steels. Solenoid valves, shipbuilding, container, railroad car construction.

Standard alloy for zinc-coated sheets and ferritic steels. Solenoid valves, joining and overlay welding on aluminium bronzes.

Seawater and corrosion resistant. Joining and overlay welding on aluminium bronzes. Solenoid valves, shipbuilding, grey cast iron, zinc-coated steels, bearing surfaces, bearing parts, fittings, pump housings.

Seawater and corrosion resistant. Joining and overlay welding on aluminium bronzes. Also suitable for zinc-coated sheets, solenoid valves, shipbuilding, bearing surfaces, bearing housings.

Seawater and corrosion resistant. Joining and overlay welding on aluminium bronzes. Solenoid valves, shipbuilding, grey cast iron, zinc-coated steels, bearing surfaces, bearing parts, fittings, pump housings.

High-strength alloy. Seawater, wear and abrasion resistant. Resistant to cavitation and erosion.

Joining and overlay welding on aluminium bronzes. Particularly suited for ship propellers, slide rails, valve gear housings.

High-strength alloy, spark discharge resistant. Seawater, wear and abrasion resistant.

Resistant to cavitation and erosion. Joining and overlay welding on aluminium bronzes.

Particularly suitable for ship propellers, slide rails, valve gear housings.

Particularly suitable for joining and overlay welding of CuNi materials having a nickel content of max. 30 %. Corrosion resistant. Shipbuilding, pipelines, chemical industry.

Particularly suitable for joining and overlay welding of CuNi materials having a nickel content of max. 30 %. Corrosion resistant. Shipbuilding, pipelines, chemical industry. Yet higher resistance to attacks of any kind.

Oxygen-containing copper alloy, particularly suited for joining and overlay welding on copper.

Oxygen-free copper alloy, particularly suited for joining and overlay welding on copper, furnace soldering, shaped solder pads.

Special alloy for solenoid valves. Also suitable for zinc-coated sheets.



## Innovative bedradox!



Opt for **bercoweld**<sup>®</sup> supplied in the innovative bedradox! Due to a high filling capacity and continuous wire pay-off, time-consuming spool changes are a thing of the past and downtimes in production are significantly reduced.

Technical data	
Width	510 mm
Height without hood	790 mm
with hood	1160 mm
with hood and pallet	1300 mm
Filling weight max	max. 200 kg
Alloys	upon request
Dimensions	0,80 - 1,60 mm



And, needless to say, the bedradox is made from recycled and recyclable cardboard. That's good for the environment and good for you as the bedradox can easily be returned into the raw material cycle.

Higher productivity with  
**bercoweld**<sup>®</sup> from the bedradox!

# Realize cost reductions when joining zinc-coated sheets

The German automotive industry has successfully led the way in joining zinc coated sheets with copper wire without extensive reworking. Subsequent processing and zinc coating of the joint is no longer necessary, while corrosion protection is still maintained. As a result, significant time and cost savings have been realized.

## Advantages of brazing with copper alloys

- excellent gap bridging
- low joining temperature
- low energy requirement
- due to lower temperature  
lower distortion of the basic material
- no zinc coating of the joint necessary

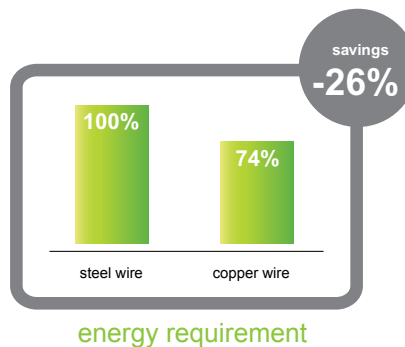
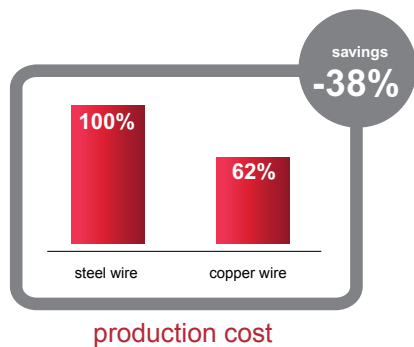

## Applications

- steel construction
- apparatus engineering
- shipbuilding
- furniture
- control cabinet
- ventilation shafts
- facades
- stairs
- sunrooms
- fences
- barriers
- building industry
- recycling systems
- truck trailer
- vehicle construction
- balcony
- carports
- store construction
- machine building
- gates
- container
- utility vehicle construction
- scales
- feed systems

## Optimize your welding and brazing processes!



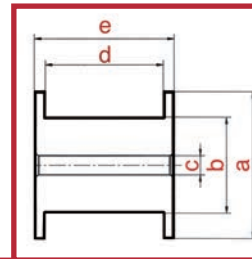

- a Flange
- b Core
- c Bore
- d Interior size
- e Exterior size

## Overview spools

Type	Material	Volume (kg)	Flange a (mm)	Core b (mm)	Bore c (mm)	Interior size d (mm)	Exterior size e (mm)
S300 (EN ISO 544)	plastic	12-15	300	212	51,5	91	103
BS300	steel	12-15	300	189	52	92	100
B300 (EN ISO 544)	steel	12-15	300	198	adaptor	90	98
H500	wood	max. 150	500	250	127	270	320
H560	wood	max. 200	560	200	127	260	320
H760	wood	max. 300	760	360	40	240	290

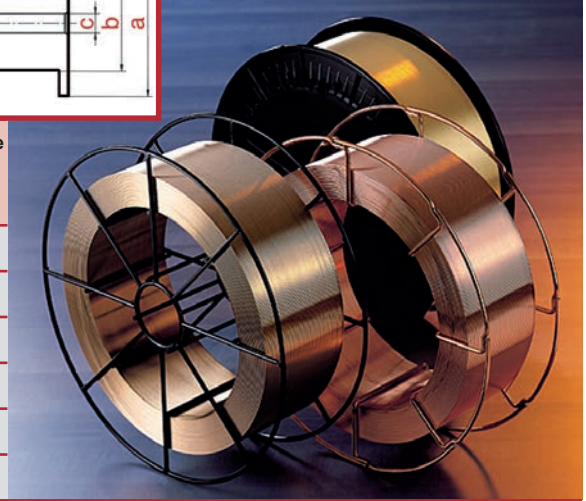

wire diameter: from 0,80 to 2,40 mm. Further dimensions on request.

## Further packagings

### Drums

**Wire diameter:**  
from 0,80 mm to 1,60 mm

**Filling weight:**  
200 kg (max.)

**Accessories:**  
plastic hood, hose pack, pay-off device

Further dimensions on request.

### Coils

**Wire diameter:**  
from 1,60 mm to 6,00 mm

**Weight:**  
from 25 to 100 kg

**Outer diameter:**  
from 450 to 600 mm

**Inner diameter:**  
from 350 to 450 mm

Further dimensions on request.

### Rods

**Wire diameter:**  
from 1,60 mm to 6,00 mm

**Length:**  
from 250 mm to 3000 mm

Cut without burrs. Rod identification possible by flat stamping.

Further dimensions on request.

### Packaging

**Spools:**  
Foil bags with silicagel in cardboard boxes

**Rods:**  
Cardboard boxes: 5 kg / 10 kg / 25 kg

**Coils:**  
Paper wrapping on request

Further packagings on request

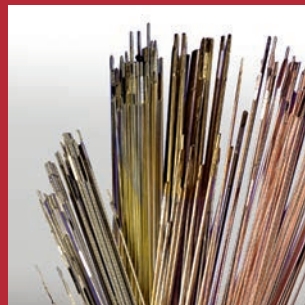

# bercoweld®

Berkenhoff GmbH  
Berkenhoffstrasse 14  
35452 Heuchelheim  
Germany  
Phone +49 641 601-0  
Fax +49 641 601-212  
info@bedra.com



[www.bercoweld.com](http://www.bercoweld.com)

**bedra**  
intelligent wires